

Antennas

Chapter 8A
Basic Amateur Radio Course
Al Penney
VO1NO

Objectives

- To become familiar with:
 - Antenna terminology;
 - Features of common antennas;
 - Antenna radiation patterns;
 - Calculating dimensions of common antennas; and
 - Construction techniques for basic antennas.

What do Antennas actually do?



Al Penney
VO1NO

What do Antennas actually do?

- They convert **Radio Frequency (RF)** energy from the transmitter into **radio waves** which are in turn **radiated** by the antenna into space.



Al Penney
VO1NO

What do Antennas actually do?

- They convert **Radio Frequency (RF)** energy from the transmitter into **radio waves** which are in turn **radiated** by the antenna into space.
- They also convert **radio waves** from free space into **electrical current** which is transformed into information by the radio.

Al Penney
VO1NO

In **radio engineering**, an **antenna** is the interface between **radio waves** propagating through space and electric currents moving in metal conductors, used with a **transmitter** or **receiver**. In **transmission**, a radio transmitter supplies an electric current to the antenna's terminals, and the antenna radiates the energy from the current as **electromagnetic waves** (radio waves). In **reception**, an antenna intercepts some of the power of a radio wave in order to produce an electric current at its terminals, that is applied to a receiver to be **amplified**. Antennas are essential components of all **radio** equipment.

Electromagnetic Waves

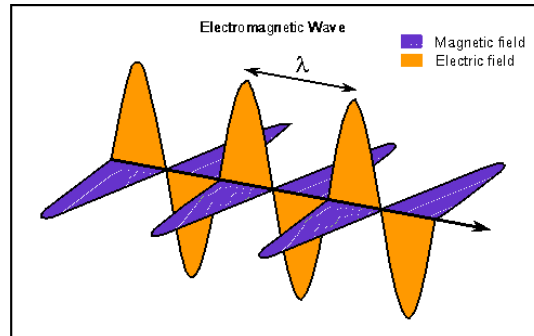

Al Penney
VO1NO

Electromagnetic Waves

- Composed of an **Electric Field (“E”)** and a **Magnetic Field (“H”)**.
- **E and H fields are transverse** – ie: they are at right angles to the direction of propagation of the wave.
- **E and H fields are mutually perpendicular.**
- The two fields are **in phase**.
- **Velocity** of an EM Wave is the **speed of light**.
- **Polarization** of the **EM wave** is defined by the orientation of the **E field**.
- **Circular Polarization** is also possible.

Al Penney
VO1NO

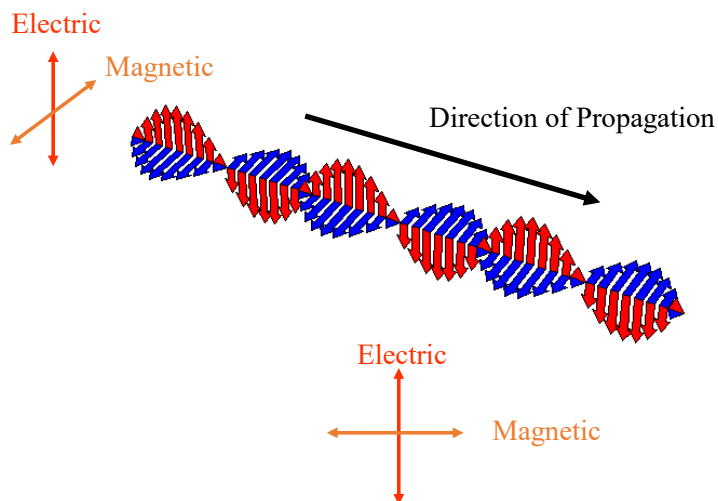

Al Penney
VO1NO

Antenna Basics

Al Penney
VO1NO

Antenna Impedance

- Just as with Transmission Lines, Antennas have an **Impedance** at their **Feedpoint**.
- Consists of at least two, sometimes three components:
 - **Ohmic Resistance;**
 - **Radiation Resistance;** and
 - **Reactance.**

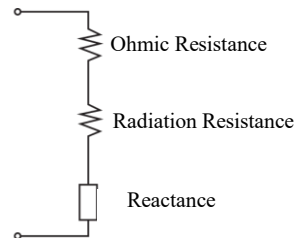

Al Penney
VO1NO

Antenna impedance may be either resistive or complex (that is, containing resistance and reactance). This will depend on whether or not the antenna is *resonant* at the operating frequency. You need to know the impedance in order to match the feeder to the feedpoint. Some operators mistakenly believe that a mismatch, however small, is a serious matter. This is not true. The importance of a matched line is described in detail in the **Transmission Lines** chapter of the ARRL Handbook. The significance

of a perfect match becomes more pronounced only at VHF and higher, where feed-line losses are a major factor. Some antennas possess a theoretical input impedance at the feedpoint close to that of certain transmission lines. For example, a 0.5λ (or half-wave) center-fed dipole placed at a correct height above ground, will have a feedpoint impedance of approximately $75\ \Omega$. In such a case it is practical to use a $75\text{-}\Omega$ coaxial or balanced line to feed the antenna. But few amateur halfwave dipoles actually exhibit a $75\text{-}\Omega$ impedance. This is because at the lower end of the high-frequency spectrum the typical height above ground is rarely more than $1/4\lambda$. The $75\text{-}\Omega$ feed-point impedance is most likely to be realized in a practical installation when the horizontal dipole is approximately $1/2$, $3/4$ or 1 wavelength above ground. Coax cable having a $50\text{-}\Omega$ characteristic impedance is the most common

transmission line used in amateur work.

A radio antenna is like any other form of RF load or signal source. It has a load or source impedance.

In order to obtain the optimum performance the antenna feeder must be matched to antenna to ensure the maximum power transfer.

Accordingly it is important to understand the feed impedance of any antenna so that the best performance can be obtained.

Antenna feed impedance basics

This impedance is known as the antenna feed impedance. It is a complex impedance and it is made up from several constituents: resistance, capacitance and inductance.

The feed impedance of the antenna results from a number of factors including the size and shape of the RF antenna, the frequency of operation and its environment. The impedance seen is normally complex, i.e. consisting of resistive elements as well as reactive ones.

Antenna feed impedance resistive elements

The resistive elements are made up from two constituents. These add together to form the sum of the total resistive elements.

•**Loss resistance:** The loss resistance arises from the actual resistance of the elements in the antenna, and power dissipated in this manner is lost as heat. Although it may appear that the "DC" resistance is low, at higher frequencies the skin effect is in evidence and only the surface areas of the conductor are used. As a result the effective resistance is higher than would be measured at DC. It is proportional to the circumference of the conductor and to the square root of the frequency.

The resistance can become particularly significant in high current sections of an RF antenna where the effective resistance is low. Accordingly to reduce the effect of the loss resistance it is necessary to ensure the use of very low resistance conductors.

•**Radiation resistance:** The other resistive element of the impedance is the "radiation resistance". This can be thought of as a virtual resistor. It arises from the fact that power is "dissipated" when it is radiated from the RF antenna. The aim is to "dissipate" as much power in this way as possible. The actual value for the radiation resistance varies from one type of antenna to another, and from one design to another. It is dependent upon a variety of factors. However a typical half wave dipole operating in free space has a radiation resistance of around 73 Ohms.

The current that flows into an antenna's feed point must be supplied at a finite voltage. The self impedance of the antenna is simply equal to the voltage applied to its feed

point divided by the current flowing into the feed point. Where the current and voltage are exactly in phase, the impedance is purely resistive, with zero reactive component. For this case the antenna is termed *resonant*. (Amateurs often use the term “resonant” rather loosely, usually meaning “nearly resonant” or “close-to resonant.”) You should recognize that an antenna *need not be resonant* in order to be an effective radiator.

THREE KEY FACTORS BEARING ON IMPEDANCE:

RESISTANCE: the “ohmic resistance” (measured in ohms - Ω) to the flow of electrons (AC or DC)

because of the inherent qualities of the metallic conductors themselves. This factor is something we can

only marginally influence in designing & building our antenna.....we basically have to accept the conditions,

the values our conductive wires have.

REACTANCE: the retardation, the “resistance” to electron flow of an **AC current** presented by the

capacitive and **inductive** characteristics of the pathway (conductor). Also measured in ohms $\{\Omega\}$.

Represents a power that is stored (retarded) in the near RF-field of the antenna.

INDUCTIVE REACTANCE (XL) = if the wire of our antenna is a bit longer than optimal for a given

frequency, inductive reactance increases.

CAPACITIVE REACTANCE (Xc) = if the wire is a bit too short, capacitive reactance increases.

At some frequencies along a radio band for our particular antenna, “reactance” will appear as an

inductive reactance; at other frequencies along the band **capacitive reactance** becomes a factor. What

we want to do is to try to get these two factors to cancel one another out .

At a specific frequency for a given length of antenna wire, both **reactances** can be made equal in

magnitude, but because they are opposite in influence they can be made to cancel one other. By canceling

the effects of these two forms of reactance, we can reduce all of these “resistances” to current flow down

to solely **ohmic resistance**.....the inherent ohmic resistance to current flow. At this specific frequency,

the **impedance** is purely resistive and the antenna is said to be **resonant**.....a condition or state where

XL and Xc cancel out one another, leaving the impedance solely based on the ***OHMIC RESISTANCE*** of the conductor (the antenna wire).

We achieve **resonance** in our wire antenna by basically shortening or lengthening the antenna wire

lengths, a process called "***trimming***" or perhaps by employing devices like "***matches***" to bring about the

best balances to cause reactance to cancel out, leaving purely ***OHMIC RESISTANCE..***

The "sweet spot" of

resonance can be affected by our choices of materials & lengths of feed lines and by the height & configuration

of the wire we use to build out antenna.

This is where using an ***antenna analyzer*** is valuable in analyzing our circuit to help us make decisions

on changes in the antenna. Using an analyzer is a topic deferred for a later class or discussion.

Ohmic Resistance

- This is a **measure of the RF energy** that is **transformed into heat** instead of being radiated as an electromagnetic wave.
- Caused by the **actual ohmic losses** in the wire or metal that makes up the antenna.
- Also caused by ohmic losses from **nearby conductors, including the earth.**
- Also referred to as **Heat Loss** or **Loss Resistance.**
- A **resistor** with the same value as the Ohmic resistance would **radiate the same amount of heat.**

Al Penney
VO1NO

Conductor Loss

An unavoidable part of the loss resistance comes from electrical resistance in the conductor the antenna is made of. Electrons moving through any metal are scattered off its **metallic crystal lattice** which also diminishes the electrons' momentum, transferring energy from the electrons to the lattice by impulse. The Ohmic resistance represents the energy lost by the electrons from collision with the metal atoms in the lattice, and the resulting vibrations of the lattice are perceived as **heat**.

Ground loss

Loss resistance can also include loss from heating the earth below the antenna and in conductive objects nearby, called *ground loss*, even though the loss is not *always* in the earth. Except for aviation, spacecraft, and maritime antennas, the majority of radio antenna power loss is *nearly* always from heating the soil. The loss results from **electrical** and **magnetic fields** generated by the antenna accelerating electrons in the soil or an adjacent conductor, such as the metal roof of a nearby building. The resulting collisions in that material generate heat similarly to the heat losses in the metal lattice of the antenna, discussed in the prior section.

These losses can be understood as disturbance of the antenna's field lines by an electric or magnetic obstacle, absorbing the fields or diverting the field lines from the most expedient route bridging the gap between one pole of the **dipole antenna** to the other pole, and thereby impeding the electrical circuit through the antenna; likewise, **electric field** lines interrupted between a **monopole antenna** and its **counterpoise** or **ground plane**.

All antennas' most intense fields are local, and rapidly diminish with distance from the antenna, so ground losses *can* be reduced or effectively eliminated if the antenna can be placed strategically far away from any electrical or magnetic obstacle. For example, **very high frequency** (VHF) quarter-wavelengths are about 5 feet (1.5 m), so a quarter-wave or half-wave VHF antenna is small enough to be feasibly mounted on a non-conducting mast several quarter-wavelengths above the earth and far from other antennas, metal-clad or cement buildings, or metal-frame structures.

In most ordinary antennas operated at amateur frequencies, the power lost as heat in the conductor does not exceed a few percent of the total power supplied to the antenna. Expressed in decibels, the loss is less than 0.1 dB. The RF loss resistance of copper wire even as small as #14 is very low compared with the radiation resistance of an antenna that is reasonably clear of surrounding objects and is not too close to the ground. You can therefore assume that the ohmic loss in a reasonably well-located antenna is negligible, and that the total resistance shown by the antenna (the feed-point resistance) is radiation resistance. As a radiator of electromagnetic waves, such an antenna is a highly efficient device.

Radiation Resistance (1)

- This is a measure of the **RF energy** that is **actually transmitted** into free space by the antenna.
- **“Virtual” resistor** - represents reduction of the electrons’ momentum due to the energy lost from creating electromagnetic waves.
- Radiation Resistance **decreases** as antennas are made **physically smaller**.

Al Penney
VO1NO

The **radiation resistance of an antenna** is defined as the equivalent **resistance** that would dissipate the same amount of power as is radiated by the **antenna**.

Radiation resistance is caused by the **radiation reaction** of the conduction electrons in the antenna. **The radiation resistance represents reduction of the electrons’ momentum due to the energy lost from creating electromagnetic waves:**

The alternation of **AC current** flowing through an antenna accelerates the electrons in its conductor, pulling them forward and backward in sync with the frequency of the current. When accelerated, electrons radiate **electromagnetic waves** which also have momentum. The momentum of the departing waves subtracts from the electrons’ momentum, causing the electrons to slow down, which is seen as a drop in voltage. That voltage drop represents radiation resistance.

The power supplied to an antenna is dissipated in two ways: radiation of electromagnetic waves, and heat losses in the wire and nearby dielectrics. The radiated power is what we want, the useful part,

but it represents a form of “loss” just as much as the power used in heating the wire or nearby dielectrics is a loss. In either case, the dissipated power is equal to I^2R . In the case of heat losses, R is a real resistance. In the case of radiation, however, R is a “virtual” resistance, which, if replaced with an actual resistor of the same value, would dissipate the power that is actually radiated from the antenna.

This resistance is called the *radiation resistance*. The total power in the antenna is therefore equal to $I^2(R_0+R)$, where R_0 is the radiation resistance and R represents the total of all the loss resistances.

Radiation Resistance (2)

- Radiation Resistance is usually much **greater than Ohmic Resistance**, but can be small in physically small antennas.
- A **resistor** with the same value as the Radiation Resistance would **dissipate the same amount of energy as is radiated by the antenna**.
- Depends partly on **antenna location with respect to nearby objects** and **the conductor's length/diameter ratio**.

Al Penney
VO1NO

The **radiation resistance of an antenna** is defined as the equivalent **resistance** that would dissipate the same amount of power as is radiated by the **antenna**.

Radiation resistance is caused by the **radiation reaction** of the conduction electrons in the antenna. **The radiation resistance represents reduction of the electrons' momentum due to the energy lost from creating electromagnetic waves:**

The alternation of **AC current** flowing through an antenna accelerates the electrons in its conductor, pulling them forward and backward in sync with the frequency of the current. When accelerated, electrons radiate **electromagnetic waves** which also have momentum. The momentum of the departing waves subtracts from the electrons' momentum, causing the electrons to slow down, which is seen as a drop in voltage. That voltage drop represents radiation resistance.

The power supplied to an antenna is dissipated in two ways: radiation of electromagnetic waves, and heat losses in the wire and nearby dielectrics. The radiated power is what we want, the useful part,

but it represents a form of “loss” just as much as the power used in heating the wire or nearby dielectrics is a loss. In either case, the dissipated power is equal to I^2R . In the case of heat losses, R is a real resistance. In the case of radiation, however, R is a “virtual” resistance, which, if replaced with an actual resistor of the same value, would dissipate the power that is actually radiated from the antenna.

This resistance is called the *radiation resistance*. The total power in the antenna is therefore equal to $I^2(R_0+R)$, where R_0 is the radiation resistance and R represents the total of all the loss resistances.

Antenna Efficiency

- Naturally, the **greater the percentage of RF energy that is radiated** as an EM wave, the **more efficient the antenna**.
- **Efficiency = $R_{\text{rad}} / (R_{\text{rad}} + R_{\text{ohmic}})$**
- As long as **R_{rad} is relatively larger than R_{ohmic}** the antenna will be **reasonably efficient**.

Al Penney
VO1NO

Efficiency

It is naturally important to ensure that the proportion of the power dissipated in the loss resistance is as low as possible, leaving the highest proportion to be dissipated in the radiation resistance as a radiated signal. The proportion of the power dissipated in the radiation resistance divided by the power applied to the antenna is the efficiency.

A variety of means can be employed to ensure that the efficiency remains as high as possible. These include the use of optimum materials for the conductors to ensure low values of resistance, large circumference conductors to ensure large surface area to overcome the skin effect, and not using designs where very high currents and low feed impedance values are present. Other constraints may require that not all these requirements can be met, but by using engineering judgement it is normally possible to obtain a suitable compromise.

It can be seen that the antenna feed impedance is particularly important when considering any RF antenna design. However by maximizing the energy transfer by matching the feeder to the antenna feed impedance the antenna design can be optimized and the best performance obtained.

Reactance (1)

- At **Resonance**, antenna **feedpoint impedance is purely resistive**, ie: it is composed of the sum of Radiation Resistance and Ohmic Resistance (Remember - At Resonance, $X_c = X_L$ leaving only resistance).
- If **used on any other frequency** however, **Reactance** becomes a component of feedpoint impedance.
- *Reactance – The opposition to the flow of Alternating Current (AC) in a circuit by storage in an electric field (for a capacitor) or a magnetic field (by an inductor). Measured in ohms.*

Al Penney
VO1NO

Antenna reactive elements

There are also reactive elements to the feed impedance. These arise from the fact that the antenna elements act as tuned circuits that possess inductance and capacitance. At resonance where most antennas are operated the inductance and capacitance cancel one another out to leave only the resistance of the combined radiation resistance and loss resistance. **However either side of resonance the feed impedance quickly becomes either inductive (if operated above the resonant frequency) or capacitive (if operated below the resonant frequency).**

There is in fact nothing magic about having a resonant antenna, provided of course that you can devise some efficient means to feed the antenna. Many amateurs use non-resonant (even random-length)

antennas fed with open-wire transmission lines and antenna tuners. They radiate signals just as well as those using coaxial cable and resonant antennas, and as a bonus they usually can use these antenna systems on multiple frequency bands. It is important to consider an antenna and its feed line as a *system*, in which all losses should be kept to a minimum.

Except at the one frequency where it is truly resonant, the current in an antenna is at a different phase compared to the applied voltage. In other words, the antenna exhibits a feed-point *impedance*, not just a pure resistance. **The feed-point impedance is composed of either capacitive or inductive reactance in series with a resistance.**

Reactance (2)

- **Below the Resonant Frequency**, feedpoint impedance consists of resistance and **capacitive reactance** (antenna is too short).
- **Above the Resonant Frequency**, feedpoint impedance consists of resistance and **inductive reactance** (antenna is too long).

Al Penney
VO1NO

REACTANCE: the retardation, the “resistance” to electron flow of an **AC current** presented by the **capacitive** and **inductive** characteristics of the pathway (conductor). Also measured in ohms $\{\Omega\}$.

Represents a power that is stored (retarded) in the near RF-field of the antenna.

INDUCTIVE REACTANCE (XL) = if the wire of our antenna is a bit longer than optimal for a given frequency, inductive reactance increases.

CAPACITIVE REACTANCE (Xc) = if the wire is a bit too short, capacitive reactance increases. At some frequencies along a radio band for our particular antenna, “reactance” will appear as an

inductive reactance; at other frequencies along the band **capacitive reactance** becomes a factor. What we want to do is to try to get these two factors to cancel one another out .

At a specific frequency for a given length of antenna wire, both **reactances** can be made equal in magnitude, but because they are opposite in influence they can be made to cancel one other. By canceling the effects of these two forms of reactance, we can reduce all of these “resistances” to current flow down to solely **ohmic resistance**.....the inherent ohmic resistance to current flow. At this specific frequency, the **impedance** is purely resistive and the antenna is said to be **resonant**.....a condition or state where XL and Xc cancel out

one another, leaving the impedance solely based on the **OHMIC RESISTANCE** of the conductor (the antenna wire).

We achieve **resonance** in our wire antenna by basically shortening or lengthening the antenna wire lengths, a process called "**trimming**" or perhaps by employing devices like "**matches**" to bring about the

best balances to cause reactance to cancel out, leaving purely **OHMIC RESISTANCE**..

The "sweet spot" of resonance can be affected by our choices of materials & lengths of feed lines and by the height & configuration of the wire we use to build out antenna.

This is where using an **antenna analyzer** is valuable in analyzing our circuit to help us make decisions on changes in the antenna. Using an analyzer is a topic deferred for a later class or discussion.

Reactance (3)

- **Reactance** does not absorb or radiate power, but can cause an **impedance mismatch** between the antenna and feedpoint.
- Reactance **can be eliminated** using capacitance or inductance, leaving just the resistive component.
 - E.g.: If antenna is **too short**, insert a **coil (inductor)** in series to **cancel** out the **capacitive reactance**.
- **An antenna does not have to be resonant to radiate!**

Typical Antenna Impedances

- Dipole, free space: 73 Ohms
- Inverted V: 50 Ohms
- Folded Dipole: 300 Ohms
- Yagi Driven Element: 25 Ohms
- Quarter Wave vertical: 36 Ohms
- Rhombic: 600 Ohms

Al Penney
VO1NO

Antenna Polarization

Vertical Polarization

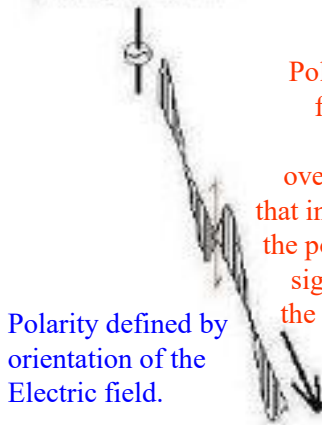

Polarity defined by orientation of the Electric field.

Horizontal Polarization

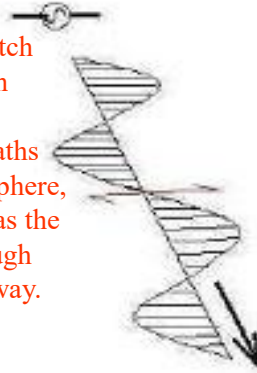

Polarity should match for best reception EXCEPT... over propagation paths that involve the ionosphere, the polarity changes as the signal travels through the ionosphere anyway.

Al Penney
VO1NO

For best results in line-of-sight communications, antennas at both ends of the circuit should have the same polarization; cross polarization results in many decibels of signal reduction. However, it is not essential for both stations to use the same antenna polarity for ionospheric propagation (sky wave). This is because the radiated wave is bent and it tumbles considerably during its travel through the ionosphere. At the far end of the communications path the wave may be horizontal, vertical or somewhere in between at any given instant. For that reason, the main consideration for a good DX antenna is a low angle of radiation rather than the polarization.

Vertical Polarization

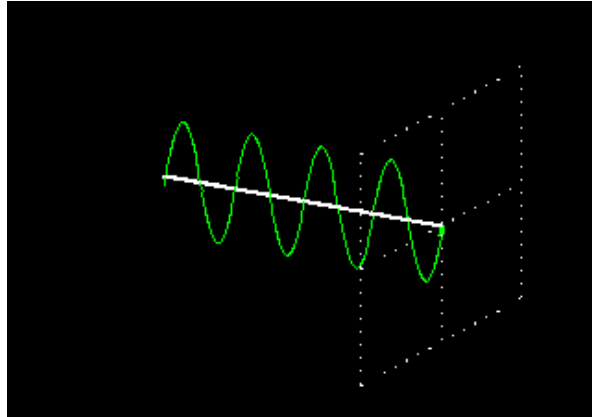

Al Penney
VO1NO

Polarity defined by orientation of the Electric Field.

Horizontal Polarization

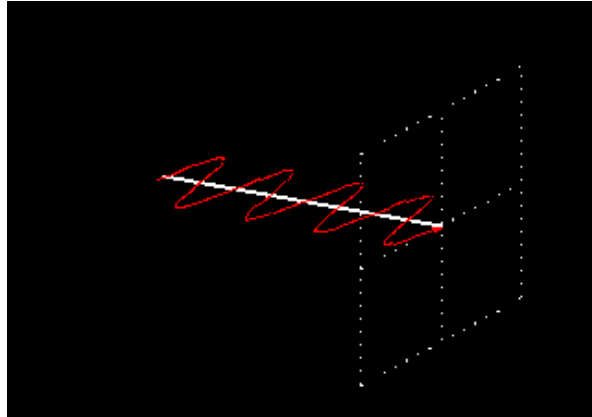

Al Penney
VO1NO

Polarity defined by orientation of the Electric Field.

Circular Polarization

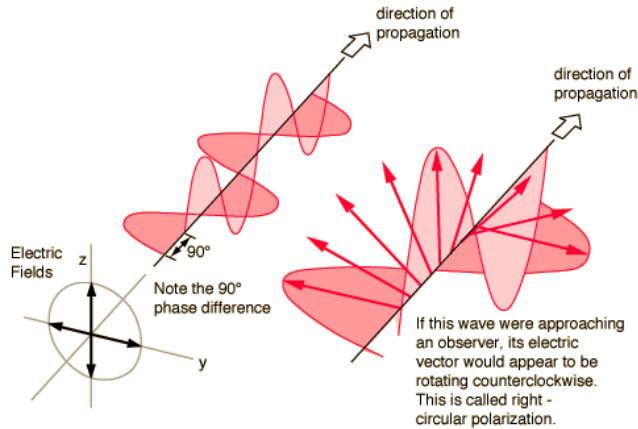

Al Penney
VO1NO

In electrodynamics, **circular polarization** of an electromagnetic wave is a polarization state in which, at each point, the electric field of the wave has a constant magnitude but its direction rotates at a constant rate in a plane perpendicular to the direction of the wave.

In electrodynamics the strength and direction of an electric field is defined by its electric field vector. In the case of a circularly polarized wave, as seen in the accompanying animation, the tip of the electric field vector, at a given point in space, describes a circle as time progresses. At any instant of time, the electric field vector of the wave indicates a point on a helix oriented along the direction of propagation. A circularly polarized wave can rotate in one of two possible senses: *right circular polarization* in which the electric field vector rotates in a right-hand sense with respect to the direction of propagation, and *left circular polarization* in which the vector rotates in a left-hand sense.

Circular Polarization

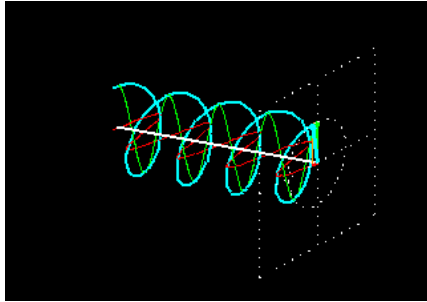

Left-Hand Circular Polarization

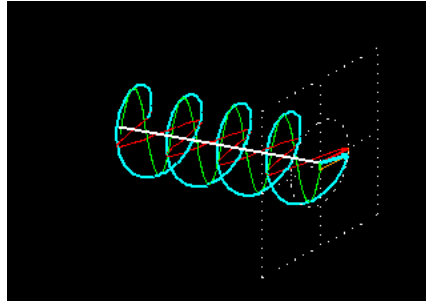

Right-Hand Circular Polarization

Note: Both TX and RX should use same polarization (LHCP or RHCP) for best results. Linearly polarized signals on one end will suffer a 3 dB signal strength loss.

Al Penney
VO1NO

Inherently Circular Polarized



Helical

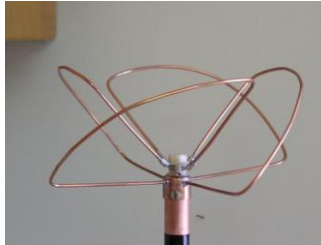

Skew Planar Wheel



Quadrifilar Helix

Al Penney
VO1NO

A **helical antenna** is an **antenna** consisting of one or more conducting wires (monofilar, bifilar, or quadrifilar with 1, 2, or 4 wires respectively) wound in the form of a **helix**. In most cases, directional helical antennas are mounted over a **ground plane**, while omnidirectional designs may not be. The **feed line** is connected between the bottom of the helix and the ground plane. Helical antennas can operate in one of two principal modes — normal mode or axial mode. In the *axial mode* or *end-fire* helical antenna, the diameter and pitch of the helix are comparable to a wavelength. The antenna functions as a **directional antenna** radiating a beam off the ends of the helix, along the antenna's axis. It radiates **circularly polarized** radio waves. These are used for satellite communication. Axial mode operation was discovered by physicist **John D. Kraus W8JK**.

Two Dipoles $\lambda/4$ Phase Difference

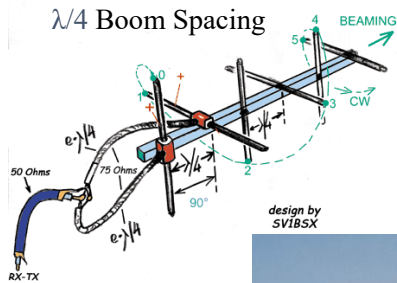

$\lambda/4$ Phasing Line



Turnstile Antenna

Al Penney
VO1NO

Isotropic Radiator

- An **imaginary** perfect antenna that **radiates equally well in all directions**.
- Used as a **base of comparison** for real antennas.
- Imagine the Sun.

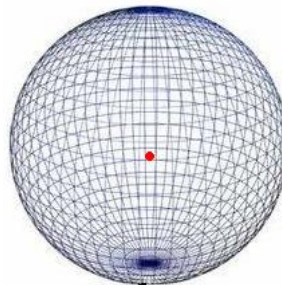
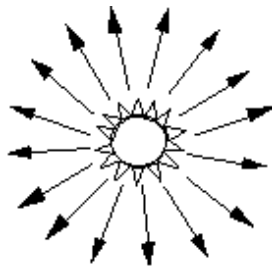

Radiation Pattern
is a sphere.

Al Penney
VO1NO

An **isotropic radiator** is a theoretical **point source** of **electromagnetic** or **sound waves** which radiates the same intensity of radiation in all directions. It has no preferred direction of radiation. It radiates uniformly in all directions over a sphere centred on the source. Isotropic radiators are used as reference radiators with which other sources are compared, for example in determining the **gain** of **antennas**. In **antenna** theory, an **isotropic antenna** is a hypothetical antenna radiating the same intensity of **radio waves** in all directions. It thus is said to have a **directivity** of **0 dBi** (**dB relative to isotropic**) in all directions.

The Isotropic Radiator

Before we can fully describe practical antennas, we must first introduce a completely theoretical antenna, the *isotropic radiator*. Envision, if you will, an infinitely small antenna, a point located in outer space, completely removed from anything else around it. Then consider an infinitely small transmitter feeding this infinitely small, point antenna. You now have an isotropic radiator.

The uniquely useful property of this theoretical *point-source* antenna is that it **radiates equally well in all directions**. That is to say, an isotropic antenna favors no direction at the expense of any other—in other words, it has absolutely no *directivity*. The

isotropic radiator is useful as a “measuring stick” for comparison with actual antenna systems.

You will find later that real, practical antennas all exhibit some degree of directivity, which is the property of radiating more strongly in some directions than in others.

The radiation from a practical

antenna never has the same intensity in all directions and may even have zero radiation in some directions. The fact that a practical antenna displays directivity (while an isotropic radiator does not) is not

necessarily a bad thing. The directivity of a real antenna is often carefully tailored to emphasize radiation in particular directions. For example, a receiving antenna that favors certain directions can discriminate against interference or noise coming from other directions, thereby increasing the signal-to-noise ratio for desired signals coming from the favored direction.

Dipole Antenna (1)

- The **half-wave dipole** antenna is an **efficient** and commonly used **practical antenna**.
- It is also used as a **comparison antenna** for gain measurements, using the term **dBd**.
- Because it **does not radiate equally well** in all directions though, it has **2.15 dB gain** compared to an isotropic antenna.
 - *Therefore Gain of a Dipole Antenna dBd = 2.15 dBi*
 - **Note that this is in free space – the presence of the Earth will change the radiation pattern of a dipole!**

Al Penney
VO1NO

The dipole antenna or dipole aerial is one of the most important forms of RF antenna. The dipole can be used on its own, or it can form part of a more complicated antenna array.

The dipole aerial or antenna is widely used on its own, but it is also incorporated into many other RF antenna designs where it forms the radiating or driven element for the overall antenna.

The dipole is relatively simple in its basic implementation and many of the basic calculations are quite straightforward. It is easy to design a basic dipole antenna that will operate on the HF, VHF and UHF sections of the radio frequency spectrum. That said, in depth mathematical analysis can require more complicated mathematical methods.

Dipole Antenna (2)

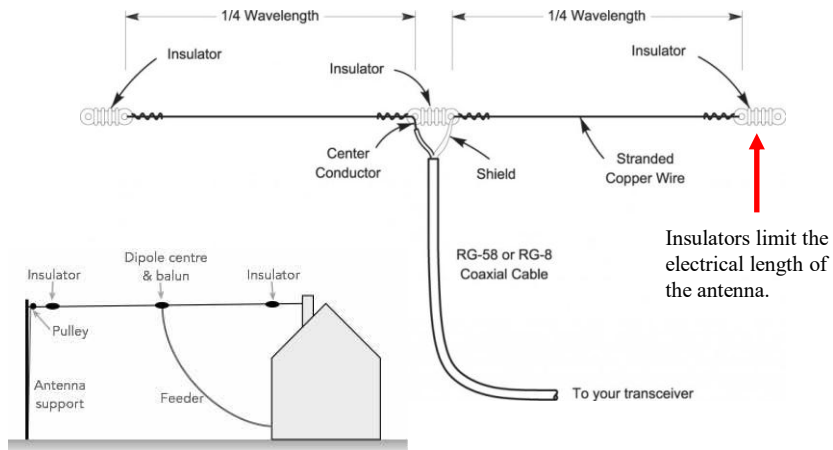

Al Penney
VO1NO

The name 'di-pole' indicates that the dipole antenna consists of two poles or items – two conductive elements.

Current flows in these two conductive elements and the current and the associated voltage causes an electromagnetic wave or radio signal to be radiated outwards from the antenna.

Dipole Antenna (3)

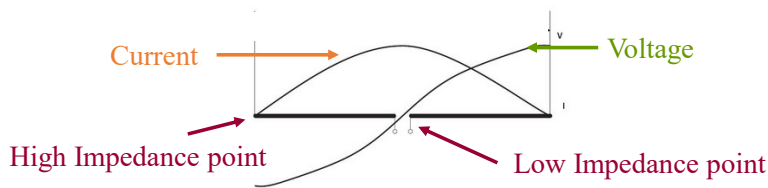

Figure . Half-Wave Dipole Antenna

- **Antenna current is high in the center** of the dipole, and **low at the ends.**
- **Voltages are high at the ends** of the dipole, and **low in the center.**
- **Center is a Low Impedance point**, while the **tips are High Impedance points.**

Al Penney
VO1NO

The current and voltage waveforms that appear along the length of a dipole antenna are of importance in many instances.

Both the dipole current and voltage waveforms may impact the way that the antenna is used, and therefore an understanding of these is important.

Dipole current & voltage

The current and voltage on any radiating element vary along its length, and this is true for the dipole as well as for any other antenna.

The current variation occurs because standing waves are set up along the length of the radiating element. This results in peaks and troughs along the length of the antenna element.

The current falls to zero at the end and then varies sinusoidally reaching a peak a quarter wavelength away from the end.

Conversely, the voltage peaks at the end and then varies as the cosine as the distance away from the end increases. It reaches a minimum a quarter wavelength from the end.

Dependent upon the length of the antenna, there may be several peaks and troughs of current and voltage along the length of the radiating element.

The most popular form of dipole antenna is the half wave and for this, the current is at a minimum at the ends and rises to a maximum in the middle where the feed is applied.

Conversely the voltage is low at the middle and rises to a maximum at the ends. It is generally fed at the centre, at the point where the current is at a maximum and the voltage a minimum. This provides a low impedance feed point which is convenient to handle. High voltage feed points are far less convenient and more difficult to use.

It is easy to remember where the current and voltage minima are. As an aide memoire it can be thought of that the voltage is at a maximum at the ends because it is the point where it is effectively open circuit, and the current is zero there, because there is nowhere for it to flow.

Dipole feed impedance basics

The dipole feed impedance is determined by the ratio of the voltage and the current at the feed point – it is simply calculated using Ohm's Law.

Although a dipole can be fed at any point, it is normal for the feed point to be at the middle of the dipole. This is the current maximum and voltage minimum point. This gives a low impedance for the dipole as can be assumed from Ohm's Law ($V / I = R$). This is far easier to accommodate than a high impedance feed impedance where very high voltages may be present when transmitting with even modest power levels.

Although the most common form of dipole is the half wave dipole, others can be multiples of a half wavelength. It is therefore possible to feed the dipole at any one of these voltage minimum or current maximum points which occur at a point that is a quarter wavelength from the end, and then at half wavelength intervals. As resonant dipoles are multiple of a half wavelength, this means that the most common point is still at the centre point of the antenna.

Dipole Antenna (4)

- Antenna impedance is **ratio of voltage and current at feed point: $Z = E/I$** .
- Most Dipoles are fed at the center, a low voltage and high current point, so impedance is low (73 Ohms in free space).
- Presence of ground and other conductors lowers a dipole's impedance.

Al Penney
VO1NO

Dipole feed impedance basics

The dipole feed impedance is determined by the ratio of the voltage and the current at the feed point – it is simply calculated using Ohm's Law.

Although a dipole can be fed at any point, it is normal for the feed point to be at the middle of the dipole. This is the current maximum and voltage minimum point. This gives a low impedance for the dipole as can be assumed from Ohm's Law ($V / I = R$). This is far easier to accommodate than a high impedance feed impedance where very high voltages may be present when transmitting with even modest power levels.

Although the most common for of dipole is the half wave dipole, others can be multiples of a half wavelength. It is therefore possible to feed the dipole at any one of these voltage minimum or current maximum points which occur at a point that is a quarter wavelength from the end, and then at half wavelength intervals. As resonant dipoles are multiple of a half wavelength, this means that the most common point is still at the centre point of the antenna.

Factors that alter the dipole feed impedance

Although the standard feed impedance of a dipole is 73Ω this value is

rarely seen as the impedance is changed by a number of different factors. One of the major factors affecting dipoles used in the HF bands can be the proximity of the ground.

For dipoles radiating at any frequency, if it forms the radiating element for a more complicated form of RF antenna, then elements of the antenna will have an effect. This normally lowers the impedance, It can fall to values of 10Ω or even less. Thus it is necessary to ensure a good match is maintained with the feeder.

Dipole Voltage/Current

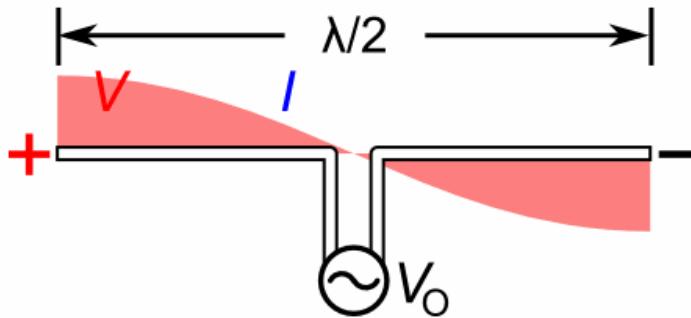

Al Penney
VO1NO

Animation showing the sinusoidal **standing waves** of voltage, V , and current, I , on a half-wave dipole driven by an AC voltage at its **resonant frequency**.

<https://owenduffy.net/blog/?p=7763>

Receiving a Signal

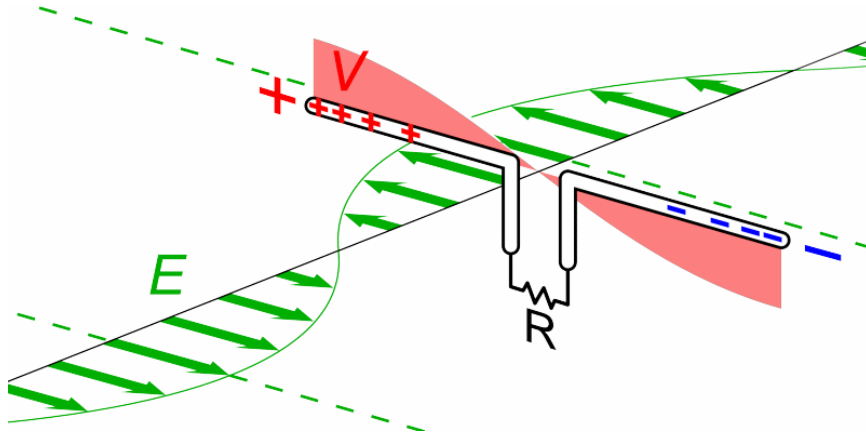

Al Penney
VO1NO

A half-wave dipole antenna receiving a radio signal. The incoming **radio wave** (whose **electric field** is shown as **E , green arrows**) causes an oscillating **electric current** within the antenna elements (**black arrows**), alternately charging the two sides of the antenna positively (+) and negatively (-). Since the antenna is one half a wavelength long at the radio wave's frequency, the voltage (shown as **V , red bands**) and current in the antenna form a **standing wave**. This oscillating current flows down the antenna's **transmission line** through the **radio receiver** (represented by resistor **R**).

Decibels (1)

- The **ratio of two power levels** can be expressed using **decibels**.
- Antenna Gain = $10 \text{ Log } \text{Power}_{\text{ref ant}} / \text{Power}_{\text{real ant}}$
- When using decibels, gain can be **added and subtracted**.
- Despite (or actually because of!) the logarithms, this is actually a **very simple system to use!!**

Al Penney
VO1NO

INTRODUCTION TO THE DECIBEL

The power gain of an antenna system is usually expressed in decibels. The decibel is a practical unit for measuring power ratios because it is more closely related to the actual effect produced at a distant receiver than the power ratio itself. One decibel represents a just-detectable change in signal strength, regardless of

the actual value of the signal voltage. A 20-decibel (20-dB) increase in signal, for example, represents 20 observable “steps” in increased signal. The power ratio

(100 to 1) corresponding to 20 dB gives an entirely exaggerated idea of the improvement in communication to be expected. The number of decibels corresponding

to any power ratio is equal to 10 times the common logarithm of the power ratio, or

$$\text{dB} = 10 \log P1/P2$$

If the voltage ratio is given, the number of decibels is equal to 20 times the common logarithm of the ratio. That is,

$$\text{dB} = 20 \log V_1/V_2$$

When a voltage ratio is used, both voltages must be measured across the same value of impedance. Unless this is done the decibel figure is meaningless, because it is fundamentally a measure of a power ratio. The main reason a decibel is used is that successive power gains expressed in decibels may simply be added together. Thus a gain of 3 dB followed by a gain of 6 dB gives a total gain of 9 dB. In ordinary power ratios, the ratios must be multiplied together to find the total gain.

A reduction in power is handled simply by subtracting the requisite number of decibels. Thus, reducing the power to $1/2$ is the same as subtracting 3 decibels. For example, a power gain of 4 in one part of a system and a reduction to $1/2$ in another part gives a total power gain of $4 \times 1/2 = 2$. In decibels, this is $6 - 3 = 3$ dB. A power reduction or "loss" is simply indicated by including a negative sign in front of the appropriate number of decibels.

Decibels (2)

- Every **3 dB change double or halves** the power.
- Every **10 db change** increases or decreases the power by **10 times**.
- *Example: An amplifier advertises that it can increase your transmit power by 6 db. If your transmitter is 50 watts, what is the output power of the amplifier?*
 - 6 db is 3 db + 3 db.
 - The first 3 db doubles your power: $50 \text{ watts} \times 2 = 100 \text{ watts}$
 - The second 3 db doubles it again: $100 \text{ watts} \times 2 = 200 \text{ watts}$

Decibels (3)

- *Example: Your feedline has 3 db loss on 2 meters. The antenna, a long boom Yagi, has a gain of 13 db compared to an isotropic antenna. If your transmitter power is 150 watts, what is your effective isotropic radiated power?*
 - 3 dB loss in the feedline = $150 \text{ watts} / 2 = 75 \text{ watts}$
 - 13 dB gain in the antenna = 10 db + 3 db
 - 10 db gain gives $75 \text{ watts} \times 10 = 750 \text{ watts}$
 - Next 3 dB gain gives $750 \text{ watts} \times 2 = 1500 \text{ watts}$
- Therefore, 150 watts into this particular antenna system is the equivalent of 1500 watts into an isotropic antenna.

Al Penney
VO1NO

Decibels (4)

- Another way to do this is to add the gain and loss of each component, and apply it to the transmitter power:
- $-3 \text{ dB} + 13 \text{ dB} = 10 \text{ dB}$ gain overall compared to an isotropic antenna.
- 10 dB gain with 150 watt transmitter gives $150 \text{ watts} \times 10 = 1500$ watts compared to an isotropic antenna.
- So the answer is the same no matter how the dB calculations are made.

Decibels (5)

• dB	<u>Power Chng</u>	• dB	<u>Power Chng</u>
• 1	1.25	• 10	10.0
• 2	1.58	• 11	12.6
• 3	2.0	• 12	15.8
• 4	2.5	• 13	20.0
• 5	3.15	• 14	25.1
• 6	4.0	• 15	31.6
• 7	5.0	• 20	100
• 8	6.3	• 30	1,000
• 9	8.0	• 40	10,000

Al Penney
VO1NO

Radiation Patterns

- Most antennas **do not transmit/receive equally well in all directions**, either in azimuth or in elevation above the horizon.
- To illustrate this behavior, we use **radiation plots**.

Radiation Patterns

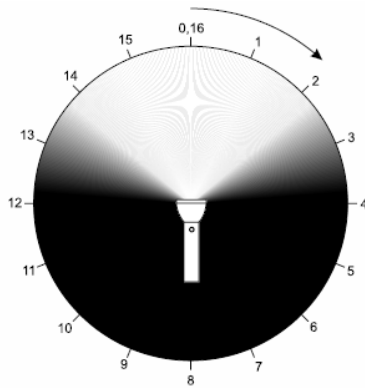

Fig 9—The beam from a flashlight illuminates a totally darkened area as shown here. Readings taken with a photographic light meter at the 16 points around the circle may be used to plot the radiation pattern of the flashlight.

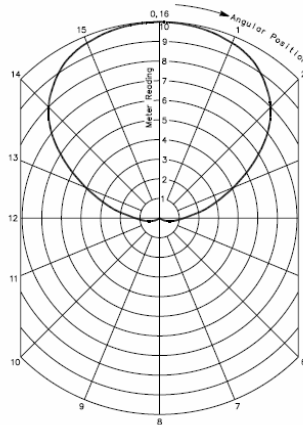

Fig 10—The radiation pattern of the flashlight in Fig 9. The measured values are plotted and connected with a smooth curve.

Al Penney
VO1NO

Directivity and the Radiation Pattern—a Flashlight Analogy

The directivity of an antenna is directly related to the *pattern* of its radiated field intensity in free space. A graph showing the actual or relative field intensity at a fixed distance, as a function of the direction from the antenna system, is called a *radiation pattern*. Since we can't actually see electromagnetic waves making up the radiation pattern of an antenna, we can consider an analogous situation.

Fig represents a flashlight shining in a totally darkened room. To quantify what our eyes are seeing, we use a sensitive light meter like those used by photographers, with a scale graduated

in units from 0 to 10. We place the meter directly in front of the flashlight and adjust the distance so the meter reads 10, exactly full scale.

We also carefully note the distance. Then, always keeping the meter the same distance from the flashlight and keeping it at the same height above the floor, we move the light meter around the flashlight, as indicated by the arrow, and take light readings at a number of different positions.

After all the readings have been taken and recorded, we plot those values on a sheet of polar graph paper, like that shown in **Fig 9**. The values read on the meter are plotted at an angular position corresponding to that for which each meter reading was taken. Following this, we connect the plotted points with a smooth curve, also shown in Fig 9. When this is finished, we have completed a radiation pattern for the flashlight.

Antenna Pattern - Isotropic

- An **imaginary** perfect antenna that **radiates equally well in all directions**.
- Used as a **base of comparison** for real antennas.

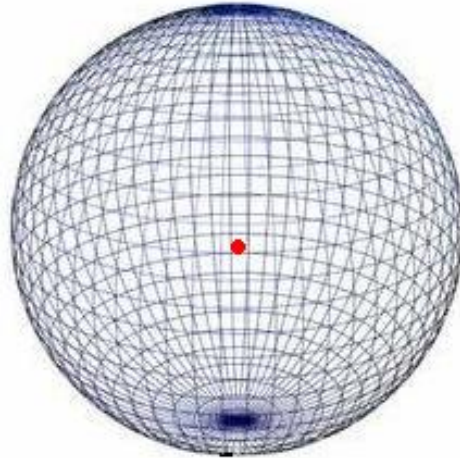

Al Penney
VO1NO

Antenna Pattern - Isotropic

- If we slice through the pattern of the Isotropic antenna, we have the following circular pattern.
- Imagine slicing an orange into two sections.

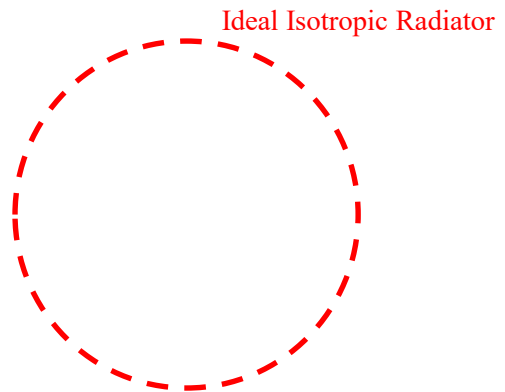

Al Penney
VO1NO

Antenna Pattern – Freespace Dipole

- A Dipole in **free space** (not affected by the ground or other nearby objects) will radiate in a “**donut**” pattern.
- **Maximum** radiation is **broadside** to the dipole.
- **Least** radiation is off the **tips**.
- Slicing the 3D pattern into two will give the “**figure 8**” pattern at right.

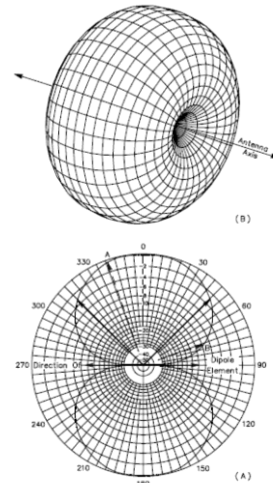

Directive diagram of a free-space dipole.

At A, the pattern in the plane containing the wire axis. The length of each dashed-line arrow represents the relative field strength in that direction, referenced to the direction of

maximum radiation, which is at right angles to the wire's axis. The arrows at approximately 45° and 315° are the half-power or -3 dB points. At B, a wire grid representation of the “solid pattern”

for the same antenna. These same patterns apply to any center-fed dipole antenna less than a half wavelength long.

Antenna Pattern – Freespace Dipole

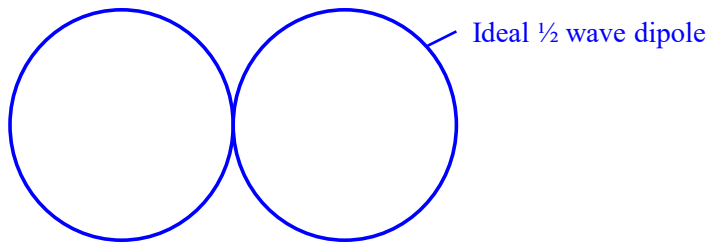

Al Penney
VO1NO

Isotropic vs Dipole - Freespace

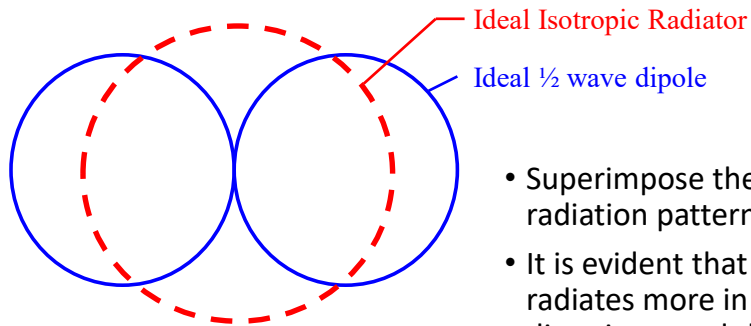

- Superimpose the two radiation patterns.
- It is evident that the dipole radiates more in some directions, and the isotropic in other directions.

Al Penney
VO1NO

Antenna Gain

- A measure of the **antenna's ability to concentrate the radiated signal** into a beam.
- Defined as the **ratio between the power** required by a **reference antenna** to produce a signal at a given location to the power required by the **real antenna** to produce the same signal in the same location.
- Always indicated as a **comparison to a standard reference antenna**, usually an **Isotropic Antenna**, or a **Dipole Antenna**.
- Gain is measured in **Decibels (dB)**.

Al Penney
VO1NO

Antenna gain tells us the power transmitted by an antenna in a specific direction as compared to an **isotropic or dipole reference antenna**. This specification describes how strong a signal an antenna can send out or receive in a specified direction.

Dipole Gain Over Isotropic

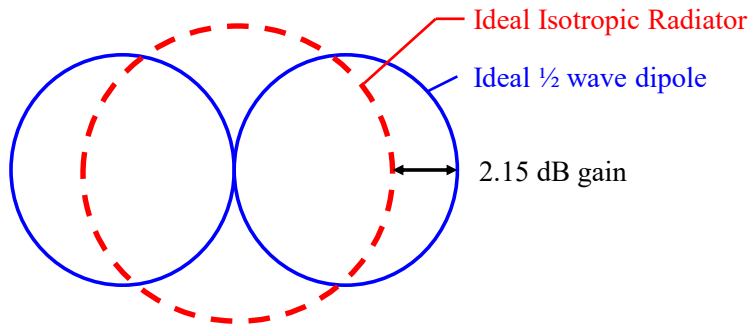

Al Penney
VO1NO

Dipole Antenna

- The **half-wave dipole** antenna is an **efficient** and commonly used **practical antenna**.
- It is also used as a **comparison antenna** for gain measurements, using the term **dBd**.
- Because it **does not radiate equally well** in all directions though, it has **2.15 dB gain** compared to an isotropic antenna.
 - *Therefore Gain of a Dipole Antenna dBd = 2.15 dBi*
 - ***Note that this is in free space – the presence of the Earth will change the radiation pattern of a dipole!***

Al Penney
VO1NO

The dipole antenna or dipole aerial is one of the most important forms of RF antenna. The dipole can be used on its own, or it can form part of a more complicated antenna array.

The dipole aerial or antenna is widely used on its own, but it is also incorporated into many other RF antenna designs where it forms the radiating or driven element for the overall antenna.

The dipole is relatively simple in its basic implementation and many of the basic calculations are quite straightforward. It is easy to design a basic dipole antenna that will operate on the HF, VHF and UHF sections of the radio frequency spectrum. That said, in depth mathematical analysis can require more complicated mathematical methods.

Practical Antenna Pattern

Antenna located here,
beaming to the right.

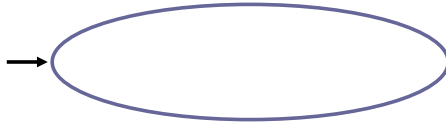

Practical antenna

Al Penney
VO1NO

Practical Antenna Pattern

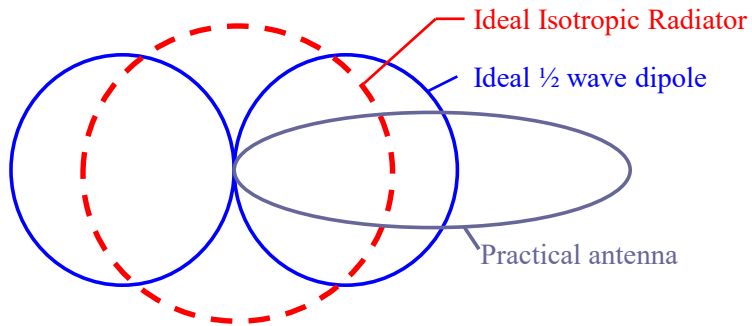

Al Penney
VO1NO

Practical Antenna Gain dBd

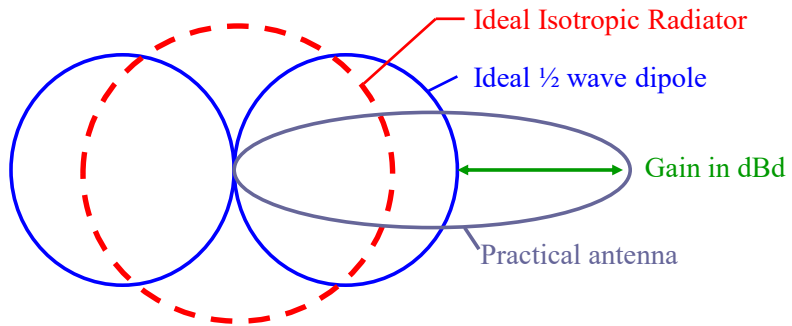

Al Penney
VO1NO

Practical Antenna Gain dBi

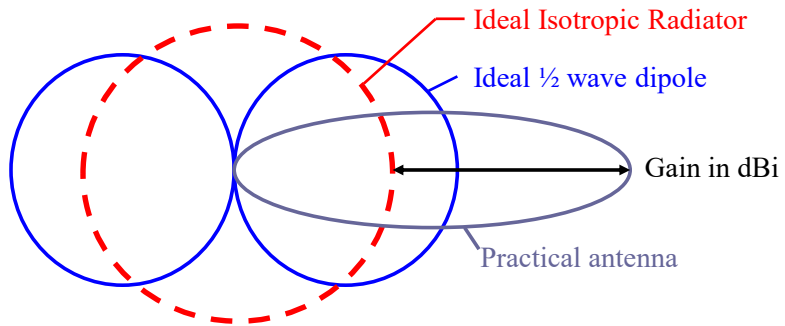

Al Penney
VO1NO

Effective Radiated Power

- The power that would have to be radiated by a half wave dipole to give the same signal strength at a distant receiver as the test antenna.
- **Equal to transmitter output power, minus line losses, plus antenna gain relative to a dipole.**

Al Penney
VO1NO

Effective Radiated Power (ERP) is the total **power** in **watts** that would have to be radiated by a **half-wave dipole antenna** to give the same radiation intensity (signal strength in watts per square meter) as the actual source at a distant receiver located in the direction of the antenna's strongest beam (**main lobe**). ERP measures the combination of the power emitted by the transmitter and the ability of the antenna to direct that power in a given direction. It is equal to the input power to the antenna multiplied by the **gain** of the antenna. It is used in electronics and **telecommunications**, particularly in **broadcasting** to quantify the apparent power of a **broadcasting station** experienced by listeners in its reception area.

An alternate parameter that measures the same thing is **effective isotropic radiated power (EIRP)**. Effective isotropic radiated power is the total power that would have to be radiated by a hypothetical **isotropic antenna** to give the same signal strength as the actual source in the direction of the antenna's strongest beam. The difference between EIRP and ERP is that ERP compares the actual antenna to a half-wave dipole antenna, while EIRP compares it to a theoretical isotropic antenna. Since a half-wave dipole antenna has a gain of 1.64, or 2.15 **decibels** compared to an isotropic radiator, if ERP and EIRP are expressed in watts their relation is

In dB, EIRP = ERP + 2.15 dB

In watts, EIRP = 1.64 x ERP

Effective Isotropic Radiated Power

- Same as ERP, but referenced to an isotropic antenna.
- In dB, EIRP = ERP + 2.15 dB
- In watts, EIRP = 1.64 x ERP

Al Penney
VO1NO

An alternate parameter that measures the same thing is **effective isotropic radiated power (EIRP)**. Effective isotropic radiated power is the total power that would have to be radiated by a hypothetical **isotropic antenna** to give the same signal strength as the actual source in the direction of the antenna's strongest beam. The difference between EIRP and ERP is that ERP compares the actual antenna to a half-wave dipole antenna, while EIRP compares it to a theoretical isotropic antenna. Since a half-wave dipole antenna has a gain of 1.64, or 2.15 **decibels** compared to an isotropic radiator, if ERP and EIRP are expressed in watts their relation is

In dB, EIRP = ERP + 2.15 dB

In watts, EIRP = 1.64 x ERP

Real Life Antennas...

- In **real life** however, we have to consider the **effect of the Earth** on the **antenna pattern**.
- Energy **reflected off the ground** reinforces the antenna's radiation pattern in some areas, and weakens it in others.
- A **dipole over salt water** might have as much as **6 dB gain** over a dipole in free space!
- The lesson to be learned here is that before comparing gain figures, you must ensure that you have **taken everything to the same baseline!**

Al Penney
VO1NO

Dipole Radiation Plot (Free Space)

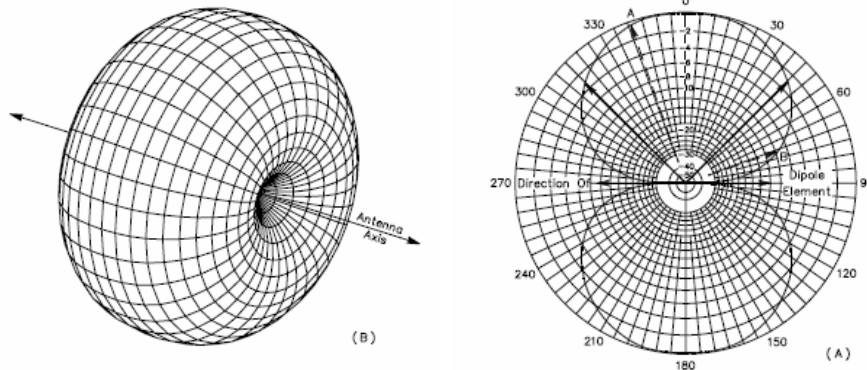

Al Penney
VO1NO

Directive diagram of a free-space dipole. At A, the pattern in the plane containing the wire axis. The length of each dashed-line arrow represents the relative field strength in that direction, referenced to the direction of maximum radiation, which is at right angles to the wire's axis. The arrows at approximately 45° and 315° are the half-power or -3 dB points. At B, a wire grid representation of the "solid pattern" for the same antenna. These same patterns apply to any center-fed dipole antenna less than a half wavelength long.

Pattern Planes

Patterns obtained above represent the antenna radiation in just one plane. In the example of the flashlight, the plane of measurement was at one height above the floor. Actually, the pattern for any antenna is three dimensional, and therefore cannot be represented in a single-plane drawing. The "solid" radiation pattern of an antenna in free space would be found by measuring the field strength at every point on the surface of an imaginary sphere having the antenna at its center. The information so obtained would then be used to construct a solid figure, where the

distance from a fixed point (representing the antenna) to the surface of the figure is proportional to the field strength from the antenna in any given direction. **Fig 11B** shows a three-dimensional wire-grid representation of the radiation pattern of a half-wave dipole.

Reflections off the Ground

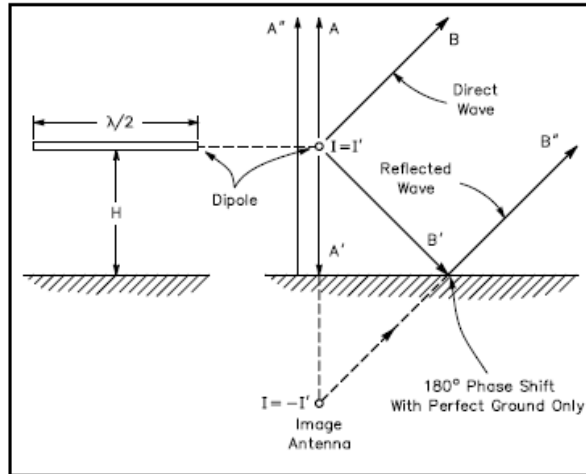

Al Penney
VO1NO

The ground acts as a mirror for radio waves. The better the ground (i.e. the more conductive it is) the more reflective it is. The direct and reflected signals will combine, giving areas radiating outwards from the antenna where signals are in phase and so reinforce each other, and areas where the signals are out of phase and so cancel each other. The phase difference depends on the difference in path length (length is directly proportional to time as the velocity is the same), and on the amount of phase shift caused by the reflection. A perfect ground causes a 180 degree shift.

Effect of the Ground

- When antenna is placed over the ground, **reflections off the ground will change the free space radiation pattern.**
- The **height of the antenna** above the ground is the **biggest factor** in determining the **new radiation pattern.**
- Conductivity of the ground also plays a part – salt water is a very good reflecting surface, while dry desert is a very poor reflector.

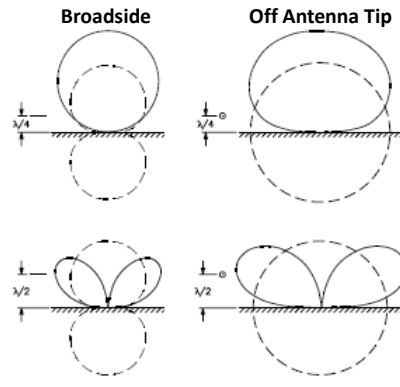

Fig 10—Effect of the ground on the radiation from a horizontal half-wave antenna, for heights of one-fourth and one-half wavelength. Broken lines show what the pattern would be if there were no reflection from the ground (free space).

Al Penney
VO1NO

Vertical Pattern

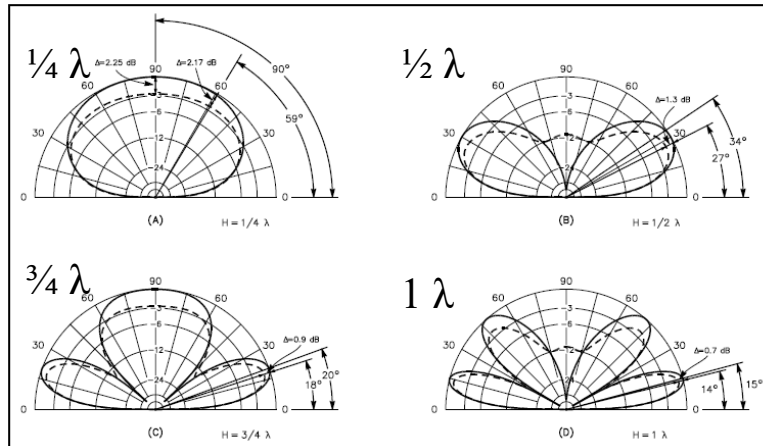

Fig 8-4 — Vertical radiation patterns over two types of earth: saltwater (solid line in each set of plots) and very poor ground (broken line in each sets of plots). The wave angles as well as the gain difference between saltwater and poor ground are given for four antenna heights.

Al Penney
VO1NO

At low height, the direct and reflected waves will cancel each other at low angles, and reinforce each other at high angles. As the height starts to increase, lower angle signals start to reinforce each other, and higher angles cancel. Thus, the radiation pattern depends primarily on the height above ground, and to a lesser extent on the quality of the ground.

Horizontal Pattern

$\frac{1}{4} \lambda$

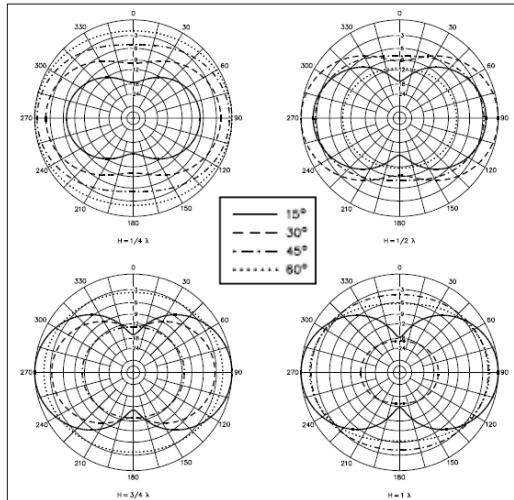

$\frac{1}{2} \lambda$

$\frac{3}{4} \lambda$

1λ

Al Penney
VO1NO

Still radiation off the ends of dipoles, especially those closer to the ground. Try to orient your dipole broadside to the directions you want to work, or put up two at right angles. If the antennas are below $\frac{1}{4}$ wavelength, then it isn't worth the bother however.

To improve the efficiency of a low dipole (less than one quarter wavelength) put wires directly under the antenna running in same direction. Remember that most of the radiation will go straight up however – an NVIS antenna (Near Vertical Incidence Skywave).

Horizontal Antenna Height

- Horizontal antennas must be mounted **at least half wavelength high to exhibit directivity.**
- At $\lambda/2$, upward radiation is **effectively cancelled.**
- Below $\lambda/2$, most radiation is directed **vertically upwards** (or absorbed in ground!).
- Going higher generates **additional lobes.**
- Height also affects feedpoint impedance.
- Situation is **different for vertical antennas!**
- **For all antennas, low angle radiation best for DX.**

Al Penney
VO1NO

The height of an antenna has a major impact on its performance. Aspects including the feed impedance, radiation diagram, radiation losses, distance from interference, reduction in possibility of exposure to RF radiation, etc.

In general the higher the antenna the better its performance will be, but sometimes there are some limits as there is a law of diminishing returns, but often this is outside the reach of amateur radio users but sometimes broadcasters will want particularly high antennas to gain the required coverage at VHF and UHF.

Broadcasters often invest in very high towers, especially for VHF and UHF broadcast transmissions. Gaining the greatest coverage area can often only be achieved by increasing the antenna height.

Antenna height at HF

Because of the wavelength of signals at HF, antennas tend to be mounted relatively close to the earth in terms of electrical wavelengths. This means that the ground interacts with the antenna, particularly a horizontal antenna in a variety of ways.

Two main factors come into play for HF antennas:

• **Angle of radiation:** For long distance communications at HF it is found

that the lower the angle of radiation of the antenna, the better it is. Many authorities on antenna design and installation recommend the antenna should be at least half a wavelength high. This can be relatively easy for frequencies say, above 15 MHz or so, but for lower frequencies with longer wavelengths this is less likely to be the case.

•In summary, the higher the horizontal antenna, the lower is the lowest lobe of the radiation pattern.

Of course a major issue is to determine exactly where the ground is. As the ground is not a perfectly conducting surface, the signal wave may penetrate the ground by a certain degree, dependent upon the type ground and its conductivity. It may be that the actual electrical ground is seen as being well below the physical earth level by the antenna. There is a degree of uncertainty as it is difficult to predict exactly how things will work out, and they may vary from day to day dependent upon the level of water in the soil at the time.

•**Radiation losses:** It is found that if a horizontal antenna gets closer to the ground, then the losses due to the ground itself become more important and, at very low heights, they can be the main factor determining antenna performance. For example for a signal at 2 MHz, the wavelength is around 150 metres. A typical radio amateur may have trouble getting a horizontal antenna for these frequencies as high as 3 or 4 metres at times. At these heights relative to a wavelength, the ground losses are most likely to be the dominant factor. It has been calculated that a 7MHz horizontal dipole antenna at a height of around 5 metres will only be around 50% efficient - half the available power will be lost as ground losses.

As a rough rule of thumb it is often said that doubling the height of an antenna will give a 6 dB increase in gain. Although this will depend upon the actual situation and a host of caveats, etc, studies have shown that it is generally not too far from the truth. At worst it gives a very good idea of the importance of raising the height of an antenna.

Height - Dipole Radiation Pattern

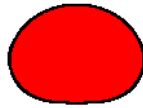

$1/8\lambda$ high



$1/4\lambda$ high



$1/2\lambda$ high



$5/8\lambda$ high



$7/8\lambda$ high



1λ high



1.25λ high



1.5λ high



2λ high

Al Penney
VO1NO

Horizontal Antennas Over Flat Ground

A simple antenna that is commonly used for HF communications is the horizontal half-wave dipole. The dipole is a straight length of wire (or tubing) into which radio-frequency energy is fed at the center. Because of its simplicity, the dipole may be easily subjected to theoretical performance analyses. Further, the results of proper analyses are well borne out in practice. For these reasons, the half-wave dipole is a convenient performance standard against which other antenna systems can be compared.

Because the earth acts as a reflector for HF radio waves, the directive properties of any antenna are modified considerably by the ground underneath it. If a dipole antenna is placed horizontally above the ground, most of the energy radiated downward from the dipole is reflected upward. The reflected waves combine with the direct waves (those radiated at angles above the horizontal) in various ways, depending on the height of the antenna, the frequency, and the electrical characteristics of the ground under and around the antenna. At some vertical angles above the horizon, the direct and reflected waves may be exactly in phase—that is, the maximum signal or field strengths of both waves are reached at the same instant at some distant point. In this case the resultant field strength is equal to the sum of the two components.

At other vertical angles the two waves may be completely out of phase at some distant point—that is, the fields are maximum at the same instant but the phase directions are opposite. The resultant field strength in this case is the difference between the two. At still other angles the resultant field will have intermediate values. Thus, the effect of the ground is to increase the intensity of radiation at some vertical angles and to decrease it at others. The elevation angles at which the maxima and minima occur depend primarily on the antenna height above ground. (The electrical characteristics of the ground have some slight effect too.)

Effect of Height – Dipole Impedance

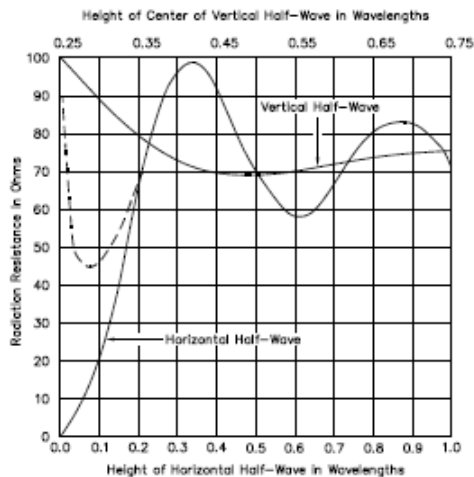

Variation in radiation resistance of vertical and horizontal half-wave antennas at various heights above flat ground. Solid lines are for perfectly conducting ground; the broken line is the radiation resistance of horizontal half-wave antennas at low heights over real ground.

Al Penney
VO1NO

This diagram shows the way in which the radiation resistance of horizontal and vertical half-wave antennas vary with height above ground (in λ , wavelengths). For horizontally polarized half-wave antennas, the differences between the effects of perfect ground and real earth are negligible if the antenna height is greater than 0.2λ . At lower heights, the feed-point resistance over perfect ground decreases rapidly as the antenna is brought closer to a theoretically perfect ground, but this does not occur so rapidly for actual ground. Over real earth, the resistance begins increasing at heights below about 0.08λ . The reason for the increasing resistance at very low heights is that more and more of the reactive (induction) field of the antenna is absorbed by the lossy ground in close proximity. For a vertically polarized $\lambda/2$ -long dipole, differences between the effects of perfect ground and real earth on the feed-point impedance is negligible, as seen in the diagram. The theoretical half-wave antennas on which this chart is based are assumed to have infinitely thin conductors.

Dipole height above ground

For larger dipole antennas like those used for frequencies below about 30 to 50 MHz, the height above ground can be a major influence on the feed

impedance.

At these frequencies the distance between the antenna and the ground may be only a wavelength or two in many instances. At these sorts of heights, the ground can have a major influence on the impedance, especially when the antenna is mounted horizontally as is often the case.

As can be seen from the impedance variation plot, the largest swings of impedance are seen when the dipole antenna is closest to the ground. It then closes in on the free space value. This means that the actual value for many HF dipoles will be relatively low as it is not possible to raise them very high in many cases. Feeding with 50Ω coaxial feeder is often a good compromise.

For VHF / UHF dipoles, it is possible to raise them much higher, although mounting poles and masts may interact to reduce the impedance. Also dipoles are not often used on their own as they are often incorporated into antennas like the Yagi.

Factors that alter the dipole feed impedance

Although the standard feed impedance of a dipole is 73Ω this value is rarely seen as the impedance is changed by a number of different factors.

One of the major factors affecting dipoles used in the HF bands can be the proximity of the ground.

For dipoles radiating at any frequency, if it forms the radiating element for a more complicated form of RF antenna, then elements of the antenna will have an effect. This normally lowers the impedance,. It can fall to values of 10 Ω or even less. Thus it is necessary to ensure a good match is maintained with the feeder.

Dipole height above ground

For larger dipole antennas like those used for frequencies below about 30 to 50 MHz, the height above ground can be a major influence on the feed impedance.

At these frequencies the distance between the antenna and the ground may be only a wavelength or two in many instances. At these sorts of heights, the ground can have a major influence on the impedance, especially when the antenna is mounted horizontally as is often the case.

As can be seen from the impedance variation plot, the largest swings of impedance are seen when the dipole antenna is closest to the ground. It then closes in on the free space value. This means that the actual value for many HF dipoles will be relatively low as it is not possible to raise them very high in many cases. Feeding with 50Ω coaxial feeder is often a good compromise.

For VHF / UHF dipoles, it is possible to raise them much higher, although mounting poles and masts may interact to reduce the impedance. Also

dipoles are not often used on their own as they are often incorporated into antennas like the Yagi.

Radiation Pattern – 3 Element Yagi

- Pattern from above at 14 degrees elevation above ground.
- Antenna beaming to 090.
- Gain is in dBi – gain compared to an isotropic antenna in free space.

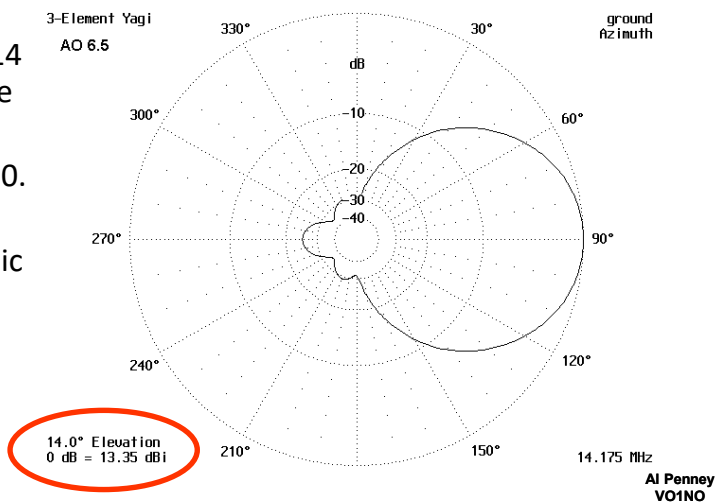

For amateur work, *relative* values of field strength (rather than absolute) are quite adequate in pattern plotting. In other words, it is not necessary to know how many microvolts per meter a particular antenna will produce at a distance of 1 mile when excited with a specified power level. (This is the kind of specifications that AM broadcast stations must meet to certify their antenna systems to the FCC.)

For whatever data is collected (or calculated from theoretical equations), it is common to normalize the plotted values so the field strength in the direction of maximum radiation coincides with the outer edge of the chart. On a given system of polar coordinate scales, the *shape* of the pattern is not altered by proper normalization, only its size.

IMPORTANT: The antenna pattern applies only to a single plane, in this case the pattern at 14 degrees elevation. We need to look at the side profile to get a complete understanding of what the antenna's radiation pattern looks like.

Radiation Pattern – 3 Element Yagi

- View from the side reveals the rest of the pattern.
- Note that there are two primary lobes in the main direction, one at 14 degrees, and the other at 44 degrees.

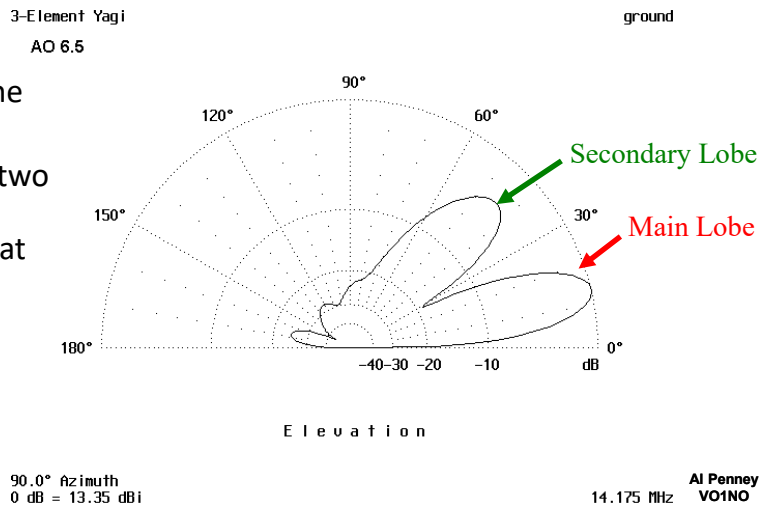

The side profile indicates that the antenna's strongest lobe is at 14 degrees, with another lobe at ~48 degrees at ~3.5 dB down from the main lobe.

6 Element Yagi vs Dipole

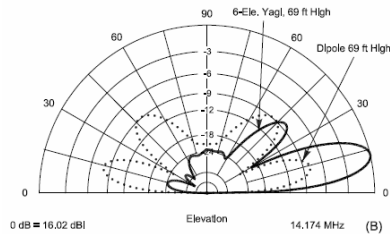
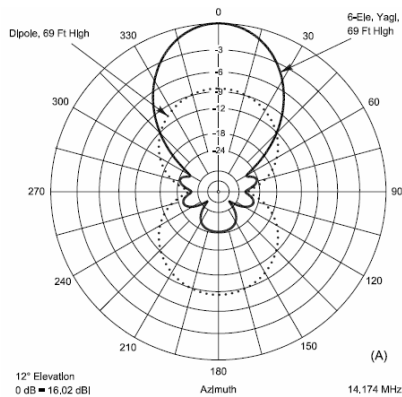

- Can also plot the pattern of an actual dipole at the same height and compare to the beam antenna pattern.
- This indicates the gain relative to an actual dipole.
- **This is NOT dBd gain however!**

Al Penney
VO1NO

We can superimpose the pattern of an actual dipole antenna at the same height of a beam (directional) antenna. This will indicate the gain of the beam antenna with respect to a dipole at the same height.

Note that this is not dBd gain however! Remember that dBd gain is the gain with respect to a dipole in FREE SPACE. The presence of the ground will affect the pattern of the actual dipole.

Antenna Beamwidth

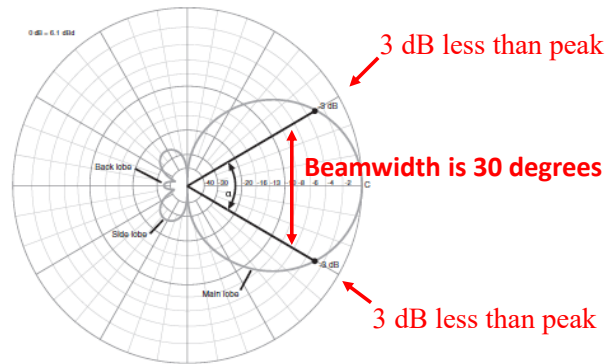

- Beamwidth is the angle between the points on the main lobe that are **3 dB down from peak strength**.

Al Penney
VO1NO

The *beamwidth* of the antenna is defined as the angle between the points on the main lobe that are 3 dB down from the peak at point C.

Front to Back Ratio (F/B Ratio)

- Ratio of power radiated in main lobe to that radiated in opposite direction (180 degrees).
- Usually expressed in decibels.

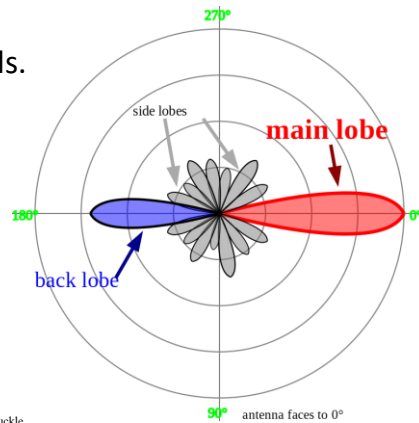

The **Front to Back Ratio (F/B Ratio)** of an antenna is the ratio of power radiated in the front/main radiation lobe and the power radiated in the opposite direction (180 degrees from the main beam).

This ratio tells us the extent of backward radiation and is normally expressed in dB. This parameter is important in circumstances where interference or coverage in the reverse direction needs to be minimized.

Antenna Bandwidth (1)

- Defined as the **frequency span** where **VSWR is 2:1 and below**.
- For a given antenna, a **larger diameter** of the antenna wire/tubing will give **greater bandwidth**.
- Difficult for a single dipole to cover the entire 80 meter band for example (3.5 – 4.0 MHz).

Al Penney
VO1NO

Bandwidth The bandwidth of an antenna refers to the range of frequencies over which the antenna can operate correctly. The antenna's bandwidth is the number of Hz for which the antenna will exhibit an SWR less than 2:1.

Antenna Bandwidth (2)

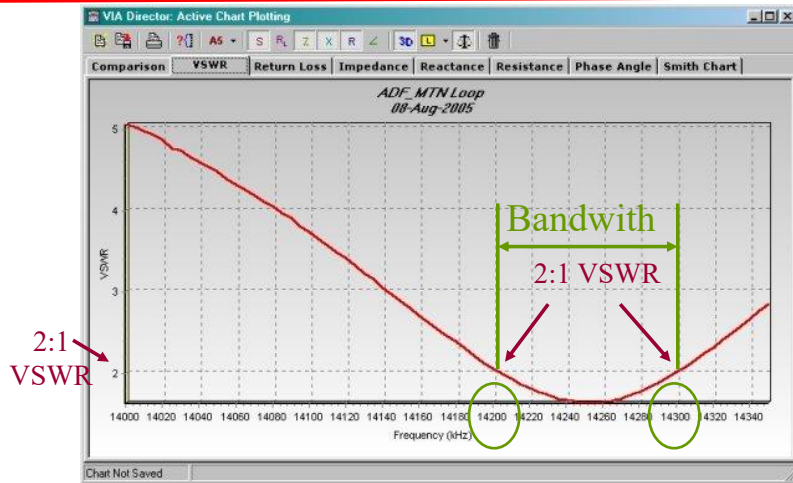

Al Penney
VO1NO

Stacking Antennas

- Antennas can be combined to **increase gain** and **improve pattern**.
- Can be **vertically** or **horizontally** stacked.
- Usually done with Yagi-Uda antennas.
- **Theoretically, gain is 3dB every time number of antennas is doubled.**
- For practical reasons, gain increase is usually **less than 3 dB – extra loss** in connectors and **non-optimum spacing** reduce gain to ~ 2.7 dB.

Al Penney
VO1NO

Parasitic arrays are commonly stacked either in broadside or collinear fashion to produce additional directivity and gain. In HF amateur work, the most common broadside stack is a vertical stack of identical Yagis on a single tower. This arrangement is commonly called a *vertical stack*. At VHF and UHF, amateurs often employ collinear stacks, where identical Yagis are stacked side-by-side at the same height. This arrangement is called a *horizontal stack*, and is not usually found at HF, because of the severe mechanical difficulties involved with large, rotatable side-by-side arrays.

Vertical vs Horizontal Stacking



Vertical Stack



Horizontal Stack

Al Penney
VO1NO

Stacked Antenna Pattern

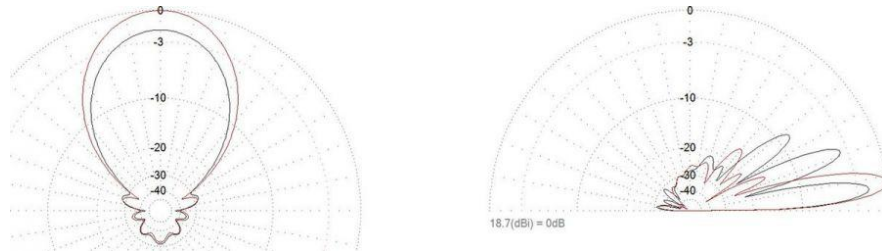

- One 7 element 20M Yagi vs two such Yagis.
- Horizontal pattern slightly broader, but vertical pattern transfers power from higher lobes into lowest.
- Gain in this case is approximately 2 dB for the pair over the single yagi.

Al Penney
VO1NO

It is a common practice these days using vertically stacked directional antennas, in particular yagi - udo type. The effect of vertical stacking was very well described by James Lawson W2PV in his historical "Yagi antenna design" book. In short the main effect is in combining radiated (received) energy from all vertical lobes into one, thus getting extra gain. Another effect of vertical stacking is not only obtaining extra gain but also widening in vertical plain the main lobe. See Fig.1 as an illustration of the two effects mentioned above.

The azimuth and vertical plane plots show the patterns of single 7 element 20m yagi at 42 meters high (black lines) and two such yagis vertically stacked at 42 and 21 meters (red lines). The stack is actually in current use at UP2L.

BS ALERT!

- Gain of 5.25 dB compared to what?? A paper clip??
- “Multiplication factor” doesn’t make sense!
- This is just a gamma-fed dipole and a vertical on the same mast!
- Meant to appeal to technically ignorant “Freeband” operators!

JGAR - HILLBILLY (HORIZONTAL - VERTICAL) ANTENNA (FREQUENCY RANGE: 26.000 - 29.500)

JGAR - HILLBILLY SPECIFICATIONS

GAIN:
Horizontal - 5.25 DB
Vertical - 4.75 DB

MULTIPLICATION
FACTOR:
Horizontal - 17X
Vertical - 15X

HORZ. to VERT.
SEPARATION:
20-25 DB

POWER RATING:
2000 CW.

WEIGHT: 10 lbs.
HEIGHT: 11 feet

MATERIALS:
Anodized
6063T-6 Aircraft
Aluminum
Tubing

REQUIRES 2
SEPARATE COAXIAL
CABLES FOR
HOOK-UP

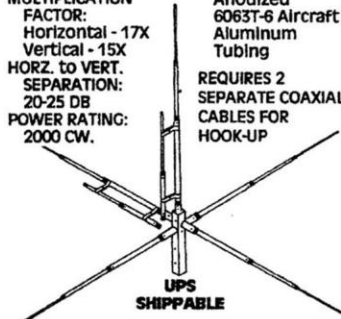

Mast Pine Diameter 17/8" O.D.

Antenna Length (1)

- In free space wavelength λ (meters) = $300/f$ (MHz).
- But, the electrical length of a conductor is affected by:
 - Speed of EM wave in that conductor;
 - Diameter/length ratio of the conductor; and
 - End effect of the insulators.
- All these factors **tend to shorten Quarter- and Half-Wavelength antennas** with respect to free space.
- On VHF / UHF antennas, the last factor does not affect antenna length much.
- Therefore, need to use **different equations for HF and VHF/UHF Quarter- and Half-Wavelength antenna lengths.**
- **NOTE: Full wavelength loop antenna use a different equation, which will be covered next lesson!**

Al Penney
VO1NO

The length of a dipole is the main consideration for determining its operating frequency, and as a result, calculating the length is a key element of designing and installing any dipole antenna whether for HF, VHF, or UHF, etc..

Most dipole antennas are a half wavelength long, and accordingly it is often necessary to calculate the physical length of a half wavelength dipole antenna.

However the physical dipole length is not exactly the same as the electrical wavelength in free space - it is slightly shorter, and it is often necessary to calculate the dipole length as best as possible.

Dipole length variation from free space length

Although the antenna may be an electrical half wavelength, or multiple of half wavelengths, this physical length is not exactly the same as the wavelength for a signal travelling in free space.

There are several reasons for this and it means that an antenna will be slightly shorter than the length calculated for a wave travelling in free space as a result of what is lightly termed the "End Effect."

The end effect results from the fact that the antenna is normally operating

surrounded by air, and the signal is travelling in a conductor which is of finite length. More specifically, the antenna end effect results from a decrease in inductance and an increase in capacitance towards the end of the antenna conductor. This serves to effectively lengthen the antenna.

It is found that the antenna end effect increases with frequency and it also varies with different installations. Wire diameter also has a marked influence on this as shown in the diagram.

For a half wave dipole the length for a wave travelling in free space is calculated and this is multiplied by a factor "A". Typically it is between 0.96 and 0.98 and is mainly dependent upon the ratio of the length of the antenna to the thickness of the wire or tube used as the element.

As a further complication, the supporting insulators, feed systems, and other surrounding objects, such as the earth, buildings, trees, etc have a noticeable effect upon the electrical length. This may even exceed the variation in length caused by practical variations in conductor diameter.

This makes an accurate length calculation difficult if not impossible to make under practical conditions. Accordingly, it is usual practice to determine the most likely length for the antenna, cut it a little longer than is expected and then check the characteristics of the antenna experimentally, altering the physical length as necessary.

Dipole length formula

a formula for the length of a dipole in feet is seen as $468 / \text{frequency}$. This can be derived by taking the figure of 492 seen in the formula above and multiplying it by the typical end effect factor of 0.95. The actual figure derived is 467.48, but this is close enough for most applications, especially as the other factors including nearby objects, etc have a significant effect on the length.

The calculations from these formulas give a good starting point for determining the length of a dipole antenna. However factors like the proximity of the ground and other nearby objects as mentioned above also have a significant impact on the length and it is not easy to determine these beforehand.

Accordingly it is always best to make any prototype antenna slightly longer than the calculations might indicate and then shorten the antenna, measuring its performance each time. In this way the optimum performance can be obtained for that antenna.

It is best to trim the antenna length in small steps because the wire or tube cannot be replaced very easily once it has been removed.

Computer simulation programmes are normally able to calculate the length of a dipole very accurately, provided that all the variables and

elements that affect the operation of the dipole can be entered accurately so that the simulation is realistic and therefore accurate. The major problem is normally being able to enter the real-life environmental data accurately to enable a realistic simulation to be undertaken.

It is relatively easy to calculate the length of an antenna in theory. In practice, many other factors have a major impact on the length. Many antenna design programmes will help reduce the errors, but in practice, it is difficult to predict the effect of buildings, trees and the general topology of the earth and how these factors will affect the antenna. It is always best to calculate the dipole length as best as possible and then adjust for optimum performance in situ.

Antenna Length (2)

- **Above 30 MHz:**

- $\lambda / 2$ (meters) = 150 / freq (MHz)
- $\lambda / 4$ (meters) = 75 / freq (MHz)

- **Or**

- $\lambda / 2$ (feet) = 492 / freq (MHz)
- $\lambda / 4$ (feet) = 246 / freq (MHz)

Antenna Length (3)

- **Below 30 MHz:**

- $\lambda / 2$ (meters) = 143 / freq (MHz)
- $\lambda / 4$ (meters) = 71.5 / freq (MHz)

- **Or**

- $\lambda / 2$ (feet) = 468 / freq (MHz)
- $\lambda / 4$ (feet) = 234 / freq (MHz)

- **Remember:**

- The **higher** the frequency, the **shorter** the antenna
- The **lower** the frequency, the **longer** the antenna.

Antenna Length Example 1

- What is length of a dipole for 21.200 MHz?

Al Penney
VO1NO

Antenna Length Example 1

- What is length of a dipole for 21.200 MHz?
- A dipole is a half wavelength antenna, and 21.200 MHz is below 30 MHz so...

Al Penney
VO1NO

Antenna Length Example 1

- What is length of a dipole for 21.200 MHz?
- A dipole is a half wavelength antenna, and 21.200 MHz is below 30 MHz so...
 - λ (meters) = $286 / \text{freq (MHz)}$

Al Penney
VO1NO

Antenna Length Example 1

- What is length of a dipole for 21.200 MHz?
- A dipole is a half wavelength antenna, and 21.200 MHz is below 30 MHz so...
 - λ (meters) = $286 / \text{freq (MHz)}$
 - $\lambda / 2$ (meters) = $143 / \text{freq (MHz)}$

Al Penney
VO1NO

Antenna Length Example 1

- What is length of a dipole for 21.200 MHz?
- A dipole is a half wavelength antenna, and 21.200 MHz is below 30 MHz so...
 - λ (meters) = $286 / \text{freq (MHz)}$
 - $\lambda / 2$ (meters) = $143 / \text{freq (MHz)}$
 - $\lambda / 2$ (meters) = $143 / 21.2$

Al Penney
VO1NO

Antenna Length Example 1

- What is length of a dipole for 21.200 MHz?
- A dipole is a half wavelength antenna, and 21.200 MHz is below 30 MHz so...
 - λ (meters) = $286 / \text{freq (MHz)}$
 - $\lambda / 2$ (meters) = $143 / \text{freq (MHz)}$
 - $\lambda / 2$ (meters) = $143 / 21.2$
 - $\lambda / 2$ (meters) = 6.74 meters

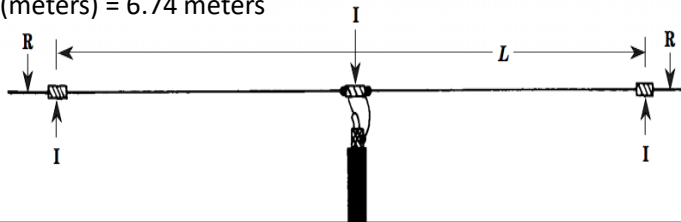

Al Penney
VO1NO

Antenna Length Example 2

- What is length of a quarter wavelength vertical for 146.520 MHz?

Al Penney
VO1NO

Antenna Length Example 2

- What is length of a quarter wavelength vertical for 146.520 MHz?
- 146.520 MHz is above 30 MHz, and wavelength λ (meters) = $300 / \text{freq (MHz)}$

Al Penney
VO1NO

Antenna Length Example 2

- What is length of a quarter wavelength vertical for 146.520 MHz?
- 146.520 MHz is above 30 MHz, and wavelength λ (meters) = $300 / \text{freq (MHz)}$
 - $\lambda / 4$ (meters) = $75 / \text{freq (MHz)}$

Al Penney
VO1NO

Antenna Length Example 2

- What is length of a quarter wavelength vertical for 146.520 MHz?
- 146.520 MHz is above 30 MHz, and wavelength λ (meters) = $300 / \text{freq (MHz)}$
 - $\lambda / 4$ (meters) = $75 / \text{freq (MHz)}$
 - $\lambda / 4$ (meters) = $75 / 146.520$

Antenna Length Example 2

- What is length of a quarter wavelength vertical for 146.520 MHz?
- 146.520 MHz is above 30 MHz, and wavelength λ (meters) = $300 / \text{freq (MHz)}$
 - $\lambda / 4$ (meters) = $75 / \text{freq (MHz)}$
 - $\lambda / 4$ (meters) = $75 / 146.520$
 - $\lambda / 4$ (meters) = 0.51 meters

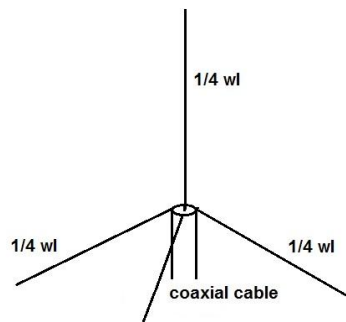

Al Penney
VO1NO

For Next Class:

- Review Chapter 8 of Basic Study Guide;
- Read the handouts; and
- Start the practice tests!



Al Penney
VO1NO

NVIS Antennas

- **Near Vertical Incidence Skywave**
- Skywave propagation 0 – 650 km.
- Signals travel **vertically or near vertically** before being refracted back to Earth.
- Suitable for 160, 80, 60 and 40M bands.
- Suitable for emergency communications and mountainous regions.

Al Penney
VO1NO

Near vertical incidence skywave, or **NVIS**, is a [skywave](#) radio-wave propagation path that provides usable signals in the distances range — usually 0–650 km (0–400 miles). It is used for military and [paramilitary](#) communications, broadcasting,^[1] especially in the tropics, and by [radio amateurs](#) for nearby contacts circumventing line-of-sight barriers. The radio waves travel near-vertically upwards into the [ionosphere](#), where they are [refracted](#) back down and can be received within a circular region up to 650 km (400 miles) from the transmitter.^[2] If the frequency is too high (that is, above the critical frequency of the ionospheric [F layer](#)), refraction fails to occur and if it is too low, absorption in the ionospheric [D layer](#) may reduce the signal strength.

There is no fundamental difference between NVIS and conventional skywave propagation; the practical distinction arises solely from different desirable radiation patterns of the antennas (near vertical for NVIS, near horizontal for conventional long-range skywave propagation).

NVIS Propagation

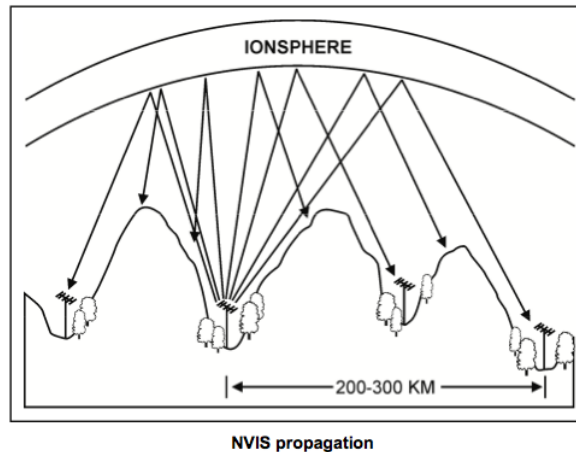

Al Penney
VO1NO

Near vertical incidence skywave, or **NVIS**, is a [skywave](#) radio-wave propagation path that provides usable signals in the distances range — usually 0–650 km (0–400 miles). It is used for military and [paramilitary](#) communications, broadcasting,^[1] especially in the tropics, and by [radio amateurs](#) for nearby contacts circumventing line-of-sight barriers. The radio waves travel near-vertically upwards into the [ionosphere](#), where they are [refracted](#) back down and can be received within a circular region up to 650 km (400 miles) from the transmitter.^[2] If the frequency is too high (that is, above the critical frequency of the ionospheric [F layer](#)), refraction fails to occur and if it is too low, absorption in the ionospheric [D layer](#) may reduce the signal strength.

There is no fundamental difference between NVIS and conventional skywave propagation; the practical distinction arises solely from different desirable radiation patterns of the antennas (near vertical for NVIS, near horizontal for conventional long-range skywave propagation).

The most reliable frequencies for NVIS communications are between 1.8 MHz and 8 MHz. Above 8 MHz, the probability of success begins to decrease, dropping to near zero at 30 MHz. Usable frequencies are dictated by local ionospheric conditions, which have a strong systematic dependence on

geographical location. Common bands used in amateur radio at mid-latitudes are 3.5 MHz at night and 7 MHz during daylight, with experimental use of 5 MHz ([60 meters](#)) frequencies. During winter nights at the bottom of the sunspot cycle, the 1.8 MHz band may be required. ^[3] Broadcasting uses the [tropical broadcast bands](#) between 2.3 and 5.06 MHz, and the [international broadcast bands](#) between 3.9 and 6.2 MHz. Military NVIS communications mostly take place on 2–4 MHz at night and on 5–7 MHz during daylight. Optimum NVIS frequencies tend to be higher towards the tropics and lower towards the arctic regions. They are also higher during high sunspot activity years. The usable frequencies change from day to night, because sunlight causes the lowest layer of the ionosphere, called the [D layer](#), to increase, causing attenuation of low frequencies during the day ^[4] while the maximum usable frequency (MUF) which is the critical frequency of the [F layer](#) rises with greater sunlight. Real time maps of the critical frequency are available. ^[5] Use of a frequency about 15% below the critical frequency should provide reliable NVIS service. This is sometimes referred to as the [optimum working frequency or FOT](#).

NVIS is most useful in mountainous areas where [line-of-sight propagation](#) is ineffective, or when the communication distance is beyond the 50 mile (80 km) range of [groundwave](#) (or the terrain is so rugged and barren that groundwave is not effective), and less than the 300–1500 mile (500–2500 km) range of lower-angle [sky-wave propagation](#). Another interesting aspect of NVIS communication is that direction finding of the sender is more difficult than for ground-wave communication (i.e. VHF or UHF). For broadcasters, NVIS allows coverage of an entire medium-sized country at much lower cost than with VHF (FM), and daytime coverage, similar to [mediumwave \(AM broadcast\)](#) nighttime coverage at lower cost and often with less interference.

Ideal NVIS Antenna Pattern

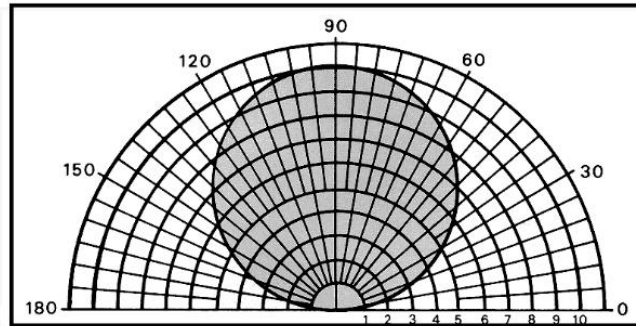
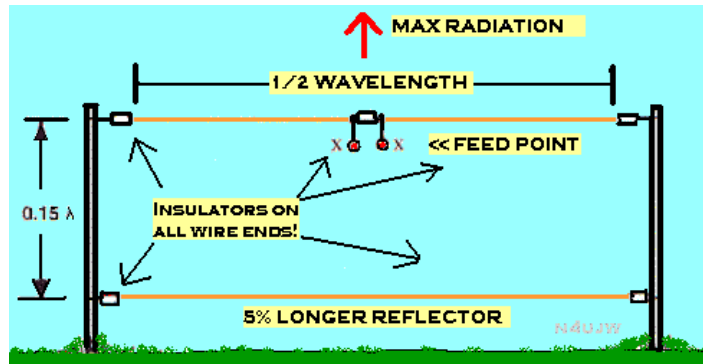

Figure M-4. Typical elevation plane pattern.

Al Penney
VO1NO

Simple NVIS Antenna



Al Penney
VO1NO

Antennas[[edit](#)]

An NVIS antenna configuration is a horizontally polarized (parallel with the surface of the earth) radiating element that is from $1/20$ th [wavelength](#) (λ) to $1/4$ wavelength above the ground. Optimum height is about $1/4$ wavelength, and high angle radiation declines only slightly for heights up to about $3/8$ wavelength. ^[6] That proximity to the ground forces the majority of the radiation to go straight up. Overall efficiency of the antenna can be increased by placing a [ground](#) wire slightly longer than the antenna parallel to and directly underneath the antenna. One source says that a single ground wire can provide antenna [gain](#) in the 3–6 dB range. ^[7] Another source indicates 2 dB for a single wire and nearly 4 dB for multiple ground wires. ^[8] Ground wires are more necessary when using lower dipoles over poor soils as without them considerable energy goes into heating the ground.

Depending on the specific requirements, various antennas (i.e.

Sloper, [T2FD](#), [Dipole](#)) can be used for NVIS communication, with horizontal dipoles or inverted V dipoles at about 0.2 wavelengths above ground giving the best results on transmit and at about 0.16 wavelengths on receive, according to military sources and an extensive study by Dutch researchers. ^[9] ^[10] Very low antennas are much inferior on transmit, less so on receive, where both

noise and signal are attenuated.

Significant increases in communication will obviously be realized when both the transmitting station and the receiving station use NVIS configuration for their antennas. In particular for low profile operations NVIS antennas are a good option.^[11]

For broadcasting, typical antennas consist of a dipole about 1/4 wavelength above ground, or arrays of such dipoles.^[12] Up to 16 dipoles can be used, allowing strong signals with relatively low power by concentrating the signal in a smaller area. Limiting the coverage may be dictated by licensing, language or political considerations. Arrays of dipoles can be used to "slew" the pattern, so that the transmitter need not be in the center of the coverage footprint. Broadcast NVIS antennas usually use an extensive ground screen to increase gain and stabilize the pattern and feed impedance with changing ground moisture.

Dual Band NVIS Antenna

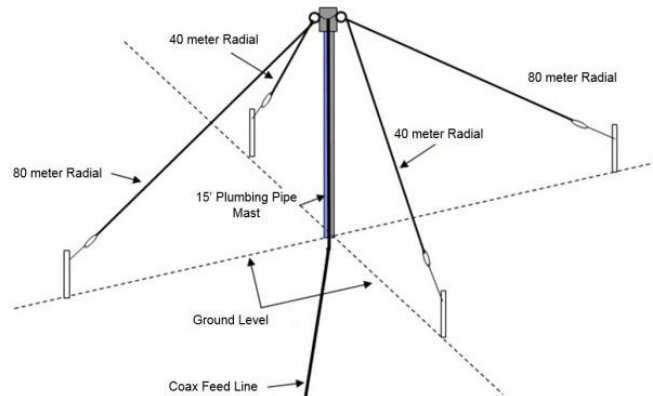

Al Penney
VO1NO

By "radial" they mean half of a dipole antenna in this illustration.

Shirley Antenna

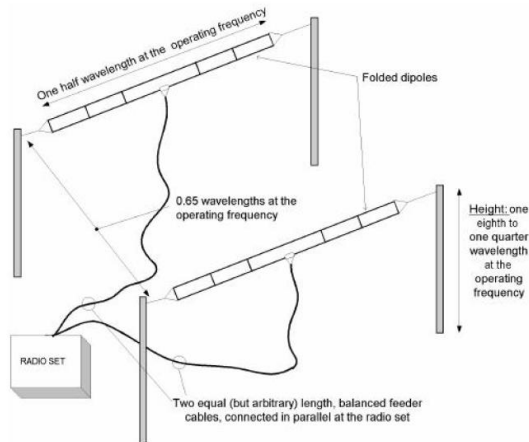

Fig.2 – a sketch

Al Penney
VO1NO

The Shirley aerial The Malayan emergency led directly to the development of perhaps the best known NVIS aerial, and one of the most efficient. This is the Shirley, which is actually two phased dipoles with the ground as a reflector; further details are given in the appendix. In some respects it is the reference aerial for NVIS work. [See Fig.2 – Ed] It was designed in about 1950 by (the then) Major John Shirley, a New Zealander who was by all accounts a most enterprising and engaging character. At the time, he was serving in the Royal Signals and on attachment to the Army Operational Research Group in Malaya. The problem was communicating with small units in the jungle. The base station, in these operations, were usually outside the main jungle and relatively static. In addition, the same frequency could be used day and night (E region propagation, possibly?) and the opposition was not thought to have much in the way of a signals intelligence capability. After some thought and research, the Shirley aerial was the result. In Shirley's own words, 'the results were spectacular'. Although troublesome to construct – a problem obviously shared with any multi-element system - the Shirley aerial remained in the Army's repertoire for many years, and probably still does. As well as being used in Malaya, a classic example of the system is given in The Vital Link3 , during the Kenyan emergency. Communication had to be established across 50-100 miles, the area including the 12,000 foot high and thickly forested Aberdare Mountains. Shirley aeriels and the A510 were used 'with good

results.'

In its original and simplest form, the Shirley aerial seems to have comprised two half wave open dipoles, fed by twin mine detonating cable. An important factor

was ease of construction from readily available stores! In this configuration, the dipoles have a rather low input impedance and there must have been mismatches all

over the place. The whole system, however, could be resonated with the aid of the output tuning circuits in the transmitter. If necessary, the length of the feeders

could be altered, by equal amounts, to enable this to be done.

A development of the original version is to raise the input impedance by using folded dipoles. 150Ω twisted feeder can then be used to give an approximate 75Ω

match. Again, it seems possible to use a variety of more or less ad hoc feeders - including lighting flex, which often has an impedance of about the right figure.

The ultimate stage, perhaps, is to make the whole thing out of 300Ω ribbon, with a balun transformer in the middle.

Jamaica Antenna

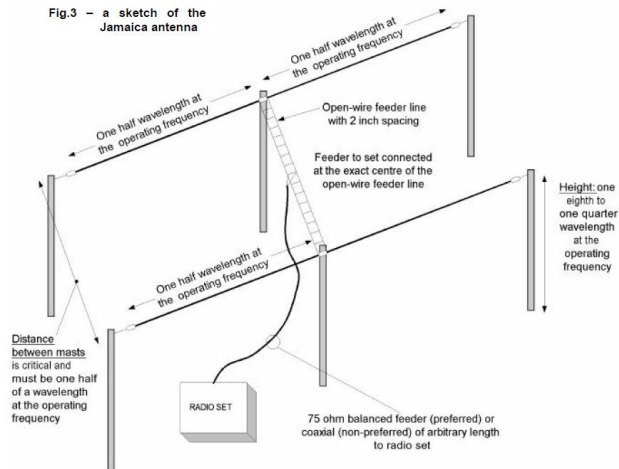

Al Penney
VO1NO

The Jamaica

A relative of the Shirley is the Jamaica, so called from its use on that island. In this case, the dipoles are full wave, but it is otherwise similar in design.

Dipole Height vs Radiation Pattern

Figure from ARRL Antenna Handbook, 22nd edition

Dipole near ground

- Higher antenna gives lower **takeoff angle**, good for DX. Rule of thumb: at least a half-wavelength above ground.
- Lower antenna is more omnidirectional in azimuth, and good for "near vertical-incidence skywave" (NVIS).
- Low antenna also called a "cloudwarmer".

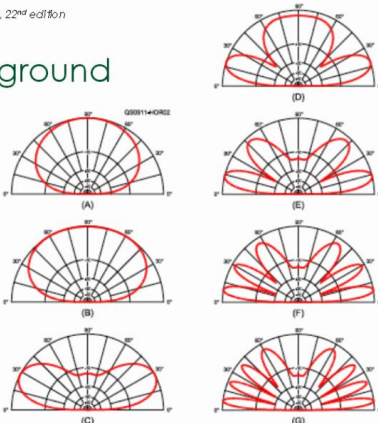

Figure 2.4 — Six radiation patterns for the dipole at different heights: (A) $\frac{1}{4} \lambda$, (B) $\frac{1}{2} \lambda$, (C) $\frac{3}{4} \lambda$, (D) 1λ , (E) $1 \frac{1}{4} \lambda$, (F) $1 \frac{1}{2} \lambda$, (G) 2λ .

Al Penney
VO1NO



Questions?

Al Penney
VO1NO

Review Question 1

Which of the following antenna system conditions will cause a modern solid-state HF transceiver to automatically reduce power?

- A Open circuit in lightning surge protector ground connection
- B Excessive antenna element movement in high winds
- C Excessive impedance mismatch between transceiver and transmission line
- D Transmitting to a balanced antenna with an unbalanced transmission line

Al Penney
VO1NO

C

Review Question 1

Which of the following antenna system conditions will cause a modern solid-state HF transceiver to automatically reduce power?

- A Open circuit in lightning surge protector ground connection
 - B Excessive antenna element movement in high winds
 - C Excessive impedance mismatch between transceiver and transmission line
 - D Transmitting to a balanced antenna with an unbalanced transmission line
-
- C Excessive impedance mismatch between transceiver and transmission line

Al Penney
VO1NO

C

Review Question 2

What does horizontal wave polarization mean?

- The electric lines of force of a radio wave are parallel to the Earth's surface
- B The electric and magnetic lines of force of a radio wave are perpendicular to the Earth's surface
- C The electric lines of force of a radio wave are perpendicular to the Earth's surface
- D The magnetic lines of force of a radio wave are parallel to the Earth's surface

Al Penney
VO1NO

A

Review Question 2

What does horizontal wave polarization mean?

- The electric lines of force of a radio wave are parallel to the Earth's surface
- B The electric and magnetic lines of force of a radio wave are perpendicular to the Earth's surface
- C The electric lines of force of a radio wave are perpendicular to the Earth's surface
- D The magnetic lines of force of a radio wave are parallel to the Earth's surface
- A The electric lines of force of a radio wave are parallel to the Earth's surface

Al Penney
VO1NO

A

Review Question 3

What does vertical wave polarization mean?

- A The electric lines of force of a radio wave are parallel to the Earth's surface
- B The electric lines of force of a radio wave are perpendicular to the Earth's surface
- C The magnetic lines of force of a radio wave are perpendicular to the Earth's surface
- D The electric and magnetic lines of force of a radio wave are parallel to the Earth's surface

Al Penney
VO1NO

B

Review Question 3

What does vertical wave polarization mean?

- A The electric lines of force of a radio wave are parallel to the Earth's surface
- B The electric lines of force of a radio wave are perpendicular to the Earth's surface
- C The magnetic lines of force of a radio wave are perpendicular to the Earth's surface
- D The electric and magnetic lines of force of a radio wave are parallel to the Earth's surface
- B The electric lines of force of a radio wave are perpendicular to the Earth's surface

Al Penney
VO1NO

B

Review Question 4

An isotropic antenna is:

- A a hypothetical point source
- B an infinitely long piece of wire
- C a dummy load
- D a half-wave reference dipole

Al Penney
VO1NO

A

Review Question 4

An isotropic antenna is:

- A a hypothetical point source
 - B an infinitely long piece of wire
 - C a dummy load
 - D a half-wave reference dipole
-
- A a hypothetical point source

Al Penney
VO1NO

A

Review Question 5

What is the three-dimensional radiation pattern of an isotropic radiator?

- A A torus (donut shape)
- B A cardioid
- C A hemisphere
- D A sphere

Al Penney
VO1NO

D

Review Question 5

What is the three-dimensional radiation pattern of an isotropic radiator?

- A A torus (donut shape)
- B A cardioid
- C A hemisphere
- D A sphere

- D A sphere

Al Penney
VO1NO

D

Review Question 6

VHF signals from a mobile station using a vertical whip antenna will normally be best received using a:

- A horizontal ground-plane antenna
- B horizontal dipole antenna
- C vertical ground-plane antenna
- D random length of wire

Al Penney
VO1NO

C

Review Question 6

VHF signals from a mobile station using a vertical whip antenna will normally be best received using a:

- A horizontal ground-plane antenna
 - B horizontal dipole antenna
 - C vertical ground-plane antenna
 - D random length of wire
-
- C vertical ground-plane antenna

Al Penney
VO1NO

C

Review Question 7

A wire dipole has a resonant frequency of 3900 kHz. How can you change its resonant frequency to 3600 kHz?

- A Use smaller diameter wire
- B Make it longer
- C Make it shorter
- D Install it as a sloper

Al Penney
VO1NO

B

Review Question 7

A wire dipole has a resonant frequency of 3900 kHz. How can you change its resonant frequency to 3600 kHz?

- A Use smaller diameter wire
 - B Make it longer
 - C Make it shorter
 - D Install it as a sloper
-
- B Make it longer

Al Penney
VO1NO

B

Review Question 8

A wire dipole has a resonant frequency of 3600 kHz. How can you change its resonant frequency to 3900 kHz?

- A Make it longer
- B Install it as a sloper
- C Use larger diameter wire
- D Make it shorter

Al Penney
VO1NO

D

Review Question 8

A wire dipole has a resonant frequency of 3600 kHz. How can you change its resonant frequency to 3900 kHz?

- A Make it longer
- B Install it as a sloper
- C Use larger diameter wire
- D Make it shorter

- D Make it shorter

Al Penney
VO1NO

D

Review Question 9

A dipole antenna will emit a vertically polarized wave if it is:

- A too near to the ground
- B very high above ground
- C mounted vertically
- D mounted horizontally

Al Penney
VO1NO

C

Review Question 9

A dipole antenna will emit a vertically polarized wave if it is:

- A too near to the ground
 - B very high above ground
 - C mounted vertically
 - D mounted horizontally
-
- C mounted vertically

Al Penney
VO1NO

C

Review Question 10

What is the wavelength in free space of a 25 MHz signal?

- A 12 metres
- B 19 metres
- C 39 metres
- D 6 metres

Al Penney
VO1NO

A

Review Question 10

What is the wavelength in free space of a 25 MHz signal?

- A 12 metres
- B 19 metres
- C 39 metres
- D 6 metres

- A 12 metres

Al Penney
VO1NO

A

Review Question 11

The velocity of propagation of radio frequency energy in free space is:

- A 150 000 kilometres per second
- B 186 000 kilometres per second
- C 300 000 kilometres per second
- D 200 000 kilometres per second

Al Penney
VO1NO

C

Review Question 11

The velocity of propagation of radio frequency energy in free space is:

- A 150 000 kilometres per second
 - B 186 000 kilometres per second
 - C 300 000 kilometres per second
 - D 200 000 kilometres per second
-
- C 300 000 kilometres per second

Al Penney
VO1NO

C

Review Question 12

If an electromagnetic wave leaves an antenna vertically polarized and reaches the receiving location by ground wave, what will be its final polarization?

- A Circular
- B Vertical
- C Oblique
- D Horizontal

Al Penney
VO1NO

B

Review Question 12

If an electromagnetic wave leaves an antenna vertically polarized and reaches the receiving location by ground wave, what will be its final polarization?

- A Circular
 - B Vertical
 - C Oblique
 - D Horizontal
-
- B Vertical

Al Penney
VO1NO

B

Review Question 13

Why are insulators used at the ends of a suspended wire antenna?

- A To reduce capacitive coupling with the ground
- B To limit the electrical length of the antenna
- C To decrease the effective antenna length
- D To increase the antenna bandwidth

Al Penney
VO1NO

B

Review Question 13

Why are insulators used at the ends of a suspended wire antenna?

- A To reduce capacitive coupling with the ground
- B To limit the electrical length of the antenna
- C To decrease the effective antenna length
- D To increase the antenna bandwidth

- B To limit the electrical length of the antenna

Al Penney
VO1NO

B

Review Question 14

Adding a series inductance to an antenna would:

- A reduce atmospheric noise pickup
- B decrease the resonant frequency
- C increase the resonant frequency
- D increase its useful bandwidth

Al Penney
VO1NO

B

Review Question 14

Adding a series inductance to an antenna would:

- A reduce atmospheric noise pickup
 - B decrease the resonant frequency
 - C increase the resonant frequency
 - D increase its useful bandwidth
-
- B decrease the resonant frequency

Al Penney
VO1NO

B

Review Question 15

What electromagnetic wave polarization does a Yagi antenna have when its elements are parallel to the Earth's surface?

- A Circular
- B Horizontal
- C Elliptical
- D Vertical

Al Penney
VO1NO

B

Review Question 15

What electromagnetic wave polarization does a Yagi antenna have when its elements are parallel to the Earth's surface?

- A Circular
 - B Horizontal
 - C Elliptical
 - D Vertical
-
- B Horizontal

Al Penney
VO1NO

B

Review Question 16

To lower the resonant frequency of an antenna, the operator should:

- A shorten it
- B use smaller diameter wire
- C lengthen the transmission line
- D lengthen it

Al Penney
VO1NO

D

Review Question 16

To lower the resonant frequency of an antenna, the operator should:

- A shorten it
- B use smaller diameter wire
- C lengthen the transmission line
- D lengthen it

- D lengthen it

Al Penney
VO1NO

D

Review Question 17

Polarization of an antenna is determined by:

- A the orientation of the electric field relative to the Earth's surface
- B the orientation of the electric field relative to the transmission line
- C the orientation of the magnetic field relative to the Earth's surface
- D the orientation of the electric field relative to the magnetic field

Al Penney
VO1NO

A

Review Question 17

Polarization of an antenna is determined by:

- A the orientation of the electric field relative to the Earth's surface
 - B the orientation of the electric field relative to the transmission line
 - C the orientation of the magnetic field relative to the Earth's surface
 - D the orientation of the electric field relative to the magnetic field
-
- A the orientation of the electric field relative to the Earth's surface

Al Penney
VO1NO

A

Review Question 18

The resonant frequency of an antenna may be increased by:

- A shortening the radiating element
- B lowering the radiating element
- C increasing the height of the radiating element
- D lengthening the radiating element

Al Penney
VO1NO

A

Review Question 18

The resonant frequency of an antenna may be increased by:

- A shortening the radiating element
 - B lowering the radiating element
 - C increasing the height of the radiating element
 - D lengthening the radiating element
-
- A shortening the radiating element

Al Penney
VO1NO

A

Review Question 19

The speed of a radio wave:

- A varies depending on the frequency
- B is the same as the speed of light
- C is constant
- D is less than half the speed of light

Al Penney
VO1NO

B

Review Question 19

The speed of a radio wave:

- A varies depending on the frequency
 - B is the same as the speed of light
 - C is constant
 - D is less than half the speed of light
-
- B is the same as the speed of light

Al Penney
VO1NO

B

Review Question 20

Compared with a horizontal antenna, a vertical antenna will receive a vertically polarized radio wave:

- A at a strength depending on the height above ground
- B at higher strength
- C at lower strength
- D at about the same strength

Al Penney
VO1NO

B

Review Question 20

Compared with a horizontal antenna, a vertical antenna will receive a vertically polarized radio wave:

- A at a strength depending on the height above ground
 - B at higher strength
 - C at lower strength
 - D at about the same strength
-
- B at higher strength

Al Penney
VO1NO

B

Review Question 21

What is meant by antenna gain?

- A The power amplifier gain minus the transmission line losses
- B The ratio of the radiated signal strength of an antenna to that of a reference antenna
- C The ratio of the signal in the forward direction to the signal in the back direction
- D The ratio of the power radiated by an antenna compared to the transmitter power

Al Penney
VO1NO

B

Review Question 21

What is meant by antenna gain?

- A The power amplifier gain minus the transmission line losses
 - B The ratio of the radiated signal strength of an antenna to that of a reference antenna
 - C The ratio of the signal in the forward direction to the signal in the back direction
 - D The ratio of the power radiated by an antenna compared to the transmitter power
-
- B The ratio of the radiated signal strength of an antenna to that of a reference antenna

Al Penney
VO1NO

B

Review Question 22

What is meant by antenna bandwidth?

- A Antenna length divided by the number of elements
- B The angle between the half-power radiation points
- C The angle formed between two imaginary lines drawn through the ends of the elements
- D The frequency range over which the antenna may be expected to perform well

Al Penney
VO1NO

D

Review Question 22

What is meant by antenna bandwidth?

- A Antenna length divided by the number of elements
- B The angle between the half-power radiation points
- C The angle formed between two imaginary lines drawn through the ends of the elements
- D The frequency range over which the antenna may be expected to perform well

- D The frequency range over which the antenna may be expected to perform well

Al Penney
VO1NO

D

Review Question 23

What is the approximate gain of a halfwave dipole in free space relative to an isotropic radiator?

- A 1.0 dB
- B 2.1 dB
- C 1.5 dB
- D 3.0 dB

Al Penney
VO1NO

B

Review Question 23

What is the approximate gain of a halfwave dipole in free space relative to an isotropic radiator?

- A 1.0 dB
 - B 2.1 dB
 - C 1.5 dB
 - D 3.0 dB
-
- B 2.1 dB

Al Penney
VO1NO

B

Review Question 24

In free space, what is the radiation pattern of a half-wave dipole?

- A Maximum radiation broadside from the antenna
- B Maximum radiation from the ends of the antenna
- C Omnidirectional radiation pattern
- D Hemispherical radiation pattern

Al Penney
VO1NO

A

Review Question 24

In free space, what is the radiation pattern of a half-wave dipole?

- A Maximum radiation broadside from the antenna
 - B Maximum radiation from the ends of the antenna
 - C Omnidirectional radiation pattern
 - D Hemispherical radiation pattern
-
- A Maximum radiation broadside from the antenna

Al Penney
VO1NO

A

Review Question 25

The gain of an antenna, especially on VHF and above, is quoted in dBi. The "i" in this expression stands for:

- A isotropic
- B integral
- C ionospheric
- D interpolated

Al Penney
VO1NO

A

Review Question 25

The gain of an antenna, especially on VHF and above, is quoted in dBi. The "i" in this expression stands for:

- A isotropic
 - B integral
 - C ionospheric
 - D interpolated
-
- A isotropic

Al Penney
VO1NO

A

Review Question 26

An antenna is said to have a gain of 4.1 dBi. How much gain is this over a half-wave dipole antenna?

- A 4.1 dB
- B 3.0 dB
- C 1.1 dB
- D 2.0 dB

Al Penney
VO1NO

D

Review Question 26

An antenna is said to have a gain of 4.1 dBi. How much gain is this over a half-wave dipole antenna?

- A 4.1 dB
- B 3.0 dB
- C 1.1 dB
- D 2.0 dB

- D 2.0 dB

Al Penney
VO1NO

D

Review Question 27

How do you calculate the approximate length in metres of a quarter-wavelength antenna for use on frequencies below 30 MHz?

- A Divide 71.3 by the operating frequency in MHz
- B Divide 468 by the operating frequency in MHz
- C Divide 300 by the operating frequency in MHz
- D Divide 143 by the operating frequency in MHz

Al Penney
VO1NO

A

Review Question 27

How do you calculate the approximate length in metres of a quarter-wavelength antenna for use on frequencies below 30 MHz?

- A Divide 71.3 by the operating frequency in MHz
 - B Divide 468 by the operating frequency in MHz
 - C Divide 300 by the operating frequency in MHz
 - D Divide 143 by the operating frequency in MHz
-
- A Divide 71.3 by the operating frequency in MHz

Al Penney
VO1NO

A

Review Question 28

If you made a quarter-wavelength vertical antenna for 21.125 MHz, approximately how long would it be?

- A 3.37 metres
- B 3.55 metres
- C 7.10 metres
- D 6.77 metres

Al Penney
VO1NO

A

Review Question 28

If you made a quarter-wavelength vertical antenna for 21.125 MHz, approximately how long would it be?

- A 3.37 metres
- B 3.55 metres
- C 7.10 metres
- D 6.77 metres

- A 3.37 metres

Al Penney
VO1NO

A

Review Question 29

If you made a half-wavelength vertical antenna for 223 MHz, approximately how long would it be?

- A 67 cm
- B 32 cm
- C 105 cm
- D 135 cm

Al Penney
VO1NO

A

Review Question 29

If you made a half-wavelength vertical antenna for 223 MHz, approximately how long would it be?

- A 67 cm
- B 32 cm
- C 105 cm
- D 135 cm

- A 67 cm

Al Penney
VO1NO

A

Review Question 30

What does "antenna front-to-back ratio" mean in reference to Yagi antenna?

- A The ratio of the power radiated by the director element, to the power radiated by the reflector element
- B The ratio of the length of the director element, to the length of the reflector element
- C The ratio of the driven element-to director spacing, to the driven element to-reflector spacing
- D The ratio of the power radiated in the forward direction to the power radiated in the opposite direction

Al Penney
VO1NO

D

Review Question 30

What does "antenna front-to-back ratio" mean in reference to Yagi antenna?

- A The ratio of the power radiated by the director element, to the power radiated by the reflector element
- B The ratio of the length of the director element, to the length of the reflector element
- C The ratio of the driven element-to director spacing, to the driven element to-reflector spacing
- D The ratio of the power radiated in the forward direction to the power radiated in the opposite direction
- D The ratio of the power radiated in the forward direction to the power radiated in the opposite direction

Al Penney
VO1NO

D

Review Question 31

How can the bandwidth of a Yagi antenna be increased?

- A Use tapered elements
- B Increase the diameter of the elements
- C Decrease the element spacing
- D Install loading coils in the elements

Al Penney
VO1NO

B

Review Question 31

How can the bandwidth of a Yagi antenna be increased?

- A Use tapered elements
 - B Increase the diameter of the elements
 - C Decrease the element spacing
 - D Install loading coils in the elements
-
- B Increase the diameter of the elements

Al Penney
VO1NO

B

Review Question 32

If the forward gain of a six-element Yagi is about 10 dBi, what would the gain of two of these antennas be if they were "stacked"?

- A 7 dBi
- B 20 dBi
- C 10 dBi
- D 13 dBi

Al Penney
VO1NO

D

Review Question 32

If the forward gain of a six-element Yagi is about 10 dBi, what would the gain of two of these antennas be if they were "stacked"?

- A 7 dBi
- B 20 dBi
- C 10 dBi
- D 13 dBi

- D 13 dBi

Al Penney
VO1NO

D

Review Question 33

If you made a half-wavelength dipole antenna for 28.150 MHz, approximately how long would it be?

- A 5.08 metres
- B 5.33 metres
- C 10.66 metres
- D 2.53 metres

Al Penney
VO1NO

A

Review Question 33

If you made a half-wavelength dipole antenna for 28.150 MHz, approximately how long would it be?

- A 5.08 metres
 - B 5.33 metres
 - C 10.66 metres
 - D 2.53 metres
-
- A 5.08 metres

Al Penney
VO1NO

A

Review Question 34

What is the three-dimensional radiation pattern of a half-wavelength dipole in free space?

- A Major lobes at 45-degree angles to the antenna
- B A torus (donut shape) around the antenna
- C A major lobe off each end of the antenna
- D Spherical (equal radiation in all directions)

Al Penney
VO1NO

B

Review Question 34

What is the three-dimensional radiation pattern of a half-wavelength dipole in free space?

- A Major lobes at 45-degree angles to the antenna
 - B A torus (donut shape) around the antenna
 - C A major lobe off each end of the antenna
 - D Spherical (equal radiation in all directions)
-
- B A torus (donut shape) around the antenna

Al Penney
VO1NO

B

Review Question 35

What is the impedance at the feed point of a half-wave dipole in free space?

- A 73 ohms
- B 52 ohms
- C 300 ohms
- D 450 ohms

Al Penney
VO1NO

A

Review Question 35

What is the impedance at the feed point of a half-wave dipole in free space?

- A 73 ohms
- B 52 ohms
- C 300 ohms
- D 450 ohms

- A 73 ohms

Al Penney
VO1NO

A

Review Question 36

Ignoring ground effects, what is the radiation pattern of a horizontal half-wave dipole installed with the ends pointing North/South?

- A Radiates mostly to the South
- B Radiates equally in all directions
- C Radiates mostly to the East and West
- D Radiates mostly to the South and North

Al Penney
VO1NO

C

Review Question 36

Ignoring ground effects, what is the radiation pattern of a horizontal half-wave dipole installed with the ends pointing North/South?

- A Radiates mostly to the South
- B Radiates equally in all directions
- C Radiates mostly to the East and West
- D Radiates mostly to the South and North

- C Radiates mostly to the East and West

Al Penney
VO1NO

C

Review Question 37

On 630 metres and 2200 metres, what key antenna characteristic must be taken into account to comply with power limitations expressed as equivalent isotropically radiated power (EIRP)?

- A Resonance
- B Gain
- C Bandwidth
- D Impedance

Al Penney
VO1NO

B

Review Question 37

On 630 metres and 2200 metres, what key antenna characteristic must be taken into account to comply with power limitations expressed as equivalent isotropically radiated power (EIRP)?

- A Resonance
- B Gain
- C Bandwidth
- D Impedance

- B Gain

Al Penney
VO1NO

B

Review Question 38

The power output from a transmitter increases from 1 watt to 2 watts. How many decibels does that increase represent?

- A 1 dB
- B 3 dB
- C 10 dB
- D 6 dB

Al Penney
VO1NO

B

Review Question 38

The power output from a transmitter increases from 1 watt to 2 watts. How many decibels does that increase represent?

- A 1 dB
- B 3 dB
- C 10 dB
- D 6 dB

- B 3 dB

Al Penney
VO1NO

B

Review Question 39

The power of your transmitter is 100 watts and your transmission line introduces a loss of 6 dB. How much power is delivered to the antenna?

- A 17 watts
- B 33 watts
- C 25 watts
- D 50 watts

Al Penney
VO1NO

C

Review Question 39

The power of your transmitter is 100 watts and your transmission line introduces a loss of 6 dB. How much power is delivered to the antenna?

- A 17 watts
- B 33 watts
- C 25 watts
- D 50 watts

- C 25 watts

Al Penney
VO1NO

C

Review Question 40

What is the wavelength in free space of a 2 MHz signal?

- A 30 metres
- B 150 metres
- C 360 metres
- D 1500 metres

Al Penney
VO1NO

B

Review Question 40

What is the wavelength in free space of a 2 MHz signal?

- A 30 metres
 - B 150 metres
 - C 360 metres
 - D 1500 metres
-
- B 150 metres

Al Penney
VO1NO

B

